

SOLID CONTROL HANDWHEEL WITH REVOLVING/FOLDING HANDLE AND LOCKING KNOB

C980



Material:

Reinforced and stabilised polyamide.
Oils and greases resistant.

Surface:

Satin.

Colour:

Black (RAL 9011).

Central Cap:

Grey polyamide (RAL 7035 cod. 13).

Main Insert:

Zinc plated steel insert with smooth through-hole (H10 tolerance).

Side Insert:

Brass right through threaded bush.

Side handle:

Revolving and folding handle M136 (pag. M-16).

Locking knob:

Cylindrical knob black (Ral 9011) art. G793-36 with threaded stud (page G-12).

Caution: the R e Q2 dimensions of the knob must be chosen by the customer according to the dimensions of the machinery on which it will be installed.

For fixing system, or execution of keyway or square holes, please refer to the technical notes attached to the catalogue.

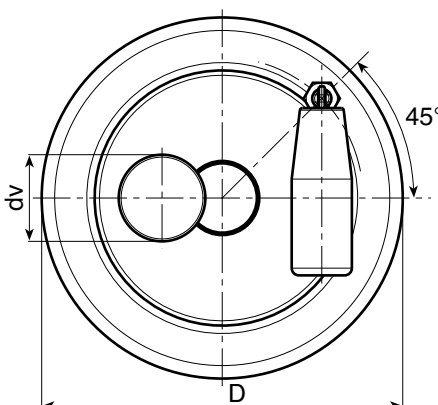
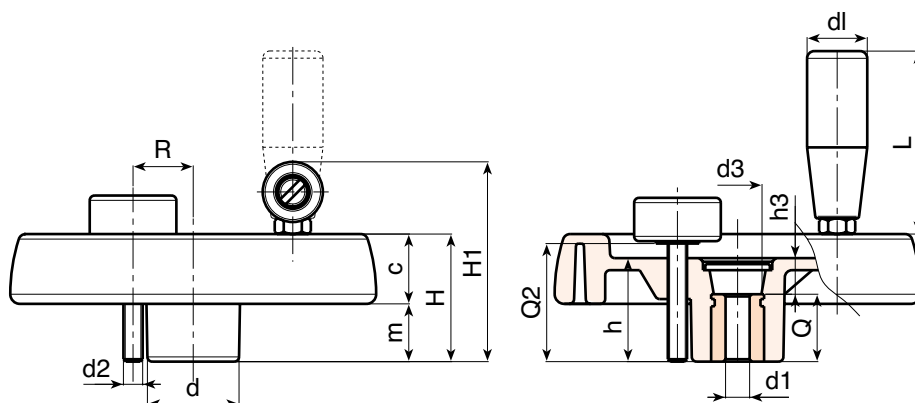

SPECIAL REQUEST:

- It's possible to supply the inserts with d1 bore by customer design, on request and for quantities.
- It's possible to supply the inserts in different material and treatment-finishes, on request and for quantities.

Version with zinc plated insert and H10 tolerance bore

Art.	D	H	H1	h	d	m	c	d3	h3	R	d2	Q2	dl	L	Dm	d1 ^{H10}	Q	△ g
● C980100.TP0501P	100	39	63	34	30	18,5	20,5	16	10	20	M6	A.R.	20	56	16	05	24	295
● C980125.TP0501P	125	44	74	37	36	20	24	26	13	22÷25	M6	A.R.	25	76	18	05	24	420
● C980150.TD0801P	150	54	89	44	38	25	29	26	12	25÷28	M8	A.R.	26	89	22	08	32	730
● C980175.TD0801P	173	57	92	47	40	25,5	31,5	26	15	26÷36	M8	A.R.	26	89	22	08	32	885
● C980200.TD0801P	202	59	94	49	44	24	35	27	13	28÷42	M8	A.R.	26	97	28	08	36	1100
● C980250.TD0801P	249	68	100	58	59	29	39	36	22	36÷50	M8	A.R.	26	97	28	08	36	1640

Attention: bore d1 (H10 tolerance) could be produced by request, with 50 pieces minimum.

Dm = It's possible to increase the hole, by boring, until Dm (enlarge). **dv** = 36 mm. **A.R.** = By request

Version with black-oxide insert and H7 tolerance bore

Art.	D	H	H1	h	d	m	c	d3	h3	R	d2	Q2	dl	L	Dm	d1 ^{H7}	Q	△ g
● C980100.TD..01PZB	100	39	63	34	30	18,5	20,5	16	10	20	M6	A.R.	20	56	16	A.R.	24	295
● C980125.TD..01PZB	125	44	74	37	36	20	24	26	13	22÷25	M6	A.R.	25	76	18	A.R.	24	420
● C980150.TD..01PZB	150	54	89	44	38	25	29	26	12	25÷28	M8	A.R.	26	89	22	A.R.	32	730
● C980175.TD..01PZB	173	57	92	47	40	25,5	31,5	26	15	26÷36	M8	A.R.	26	89	22	A.R.	32	885
● C980200.TD..01PZB	202	59	94	49	44	24	35	27	13	28÷42	M8	A.R.	26	97	28	A.R.	36	1100
● C980250.TD..01PZB	249	68	100	58	59	29	39	36	22	36÷50	M8	A.R.	26	97	28	A.R.	36	1640

Attention: replace the two places in the code .. with the hole diameter required - 50 pieces minimum.

Dm = It's possible to increase the hole, by boring, until Dm (enlarge). **dv** = 36 mm. **A.R.** = By request

Presumable presence in the stock in %

() 90% (●) 40% (●) 5% (●)

BOTECO® - © All right reserved - www.boteco.it
Any unauthorized reproduction is strictly forbidden



BOTECO