

**UNIMOTION**



**UNIMOTION**  

---

**LINEAR UNITS**

## CHARACTERISTICS

The **CTV** series describes Linear Units with a precision ball screw drive and two parallel, integrated, Zero-backlash rail guides. Compact dimensions allow high performance features such as, high speeds, good accuracy and repeatability.

They can easily be combined to multi-axis systems.

Excellent price-/performance ratio and quick delivery time are ensured.

The compact, precision-extruded aluminum Profile from AL 6063, with two parallel, integrated, Zero-backlash rail guide systems, allows high load capacities and optimal cycles for the movement of larger masses at high speed.

In the Linear Units CTV a precision ball screw, with tolerance class ISO7 ( ISO5 on request), with reduced backlash of the ball nut is used.

Two parallel circulating antistatic polyurethane sealing strips and an aluminum cover are ensuring to protect all the parts in the profile from dust and other contaminations.

Different carriage lengths with lubrication port allows for easy re-lubrication of the ball screw and Ball rail guide system and allows the possibility to attach additional accessories. The re-lubrication can also be done through maintenance holes on the side of the Profile.

The aluminum profile includes T-slots for fixing the Linear Unit and for attaching sensors and switches. Also, a Reed switch can be used here.

For the linear units CTV various adaptation options, for attaching (or redirecting), for Motors or Gearboxes are available.



**i** The aluminium profiles are manufactured according to the medium EN 12020-2 standard

Straightness = 0,35 mm/m; Max. torsion = 0,35 mm/m; Angular torsion = 0,2 mm/40 mm; Parallelism = 0,2 mm

STRUCTURAL DESIGN

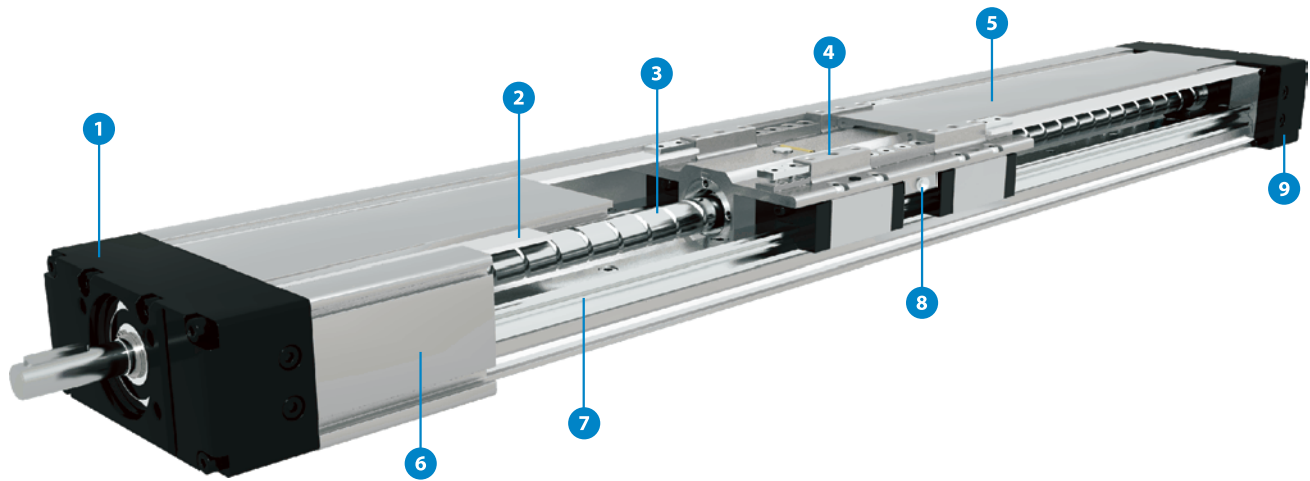

- 1 - Drive block with floating bearing
- 2 - Gap-type seal of antistatic PU strip (recirculating)
- 3 - Ball screw tolerance ISO7 (ISO5 available on request)
- 4 - Carriage; with built in Magnets
- 5 - Aluminum cover
- 6 - Aluminium profile-Hard anodized
- 7 - Two integrated Linear Ball Guideways
- 8 - Central lubrication port; both sides
- 9 - End block with fixed bearing

CTV - 110 - 1610 - ISO7 - 1 - 1000 - L - 1 - 1

Series: \_\_\_\_\_  
CTV

Size: \_\_\_\_\_  
90  
110  
145  
200

Ball screw : \_\_\_\_\_  
CTV 90: Ø12×5, Ø12×10  
CTV 110: Ø16×5, Ø16×10, Ø16×16  
CTV 145: Ø20×5, Ø20×10, Ø20×20, Ø20×50  
CTV 200: Ø32×5, Ø32×10, Ø32×20, Ø32×32

Ball screw tolerance : \_\_\_\_\_  
ISO7 (Standard)  
ISO5

Ball screw journal : \_\_\_\_\_  
0 : Without keyway  
1 : With keyway  
**i** CTV 90 only available without keyway - 0

Absolute stroke (mm) : \_\_\_\_\_  
(Absolute stroke = Effective stroke + 2 x Safety stroke)

Carriage Version : \_\_\_\_\_  
S : Short  
L : Long

Connection plate : \_\_\_\_\_  
0 : Without  
1 : With

Protection cover : \_\_\_\_\_  
0 : Without antistatic PU Gap-type seal strip  
1 : With antistatic PU Gap-type seal strip (Standard)  
2 : With Corrosion-resistant protection strip

**TECHNICAL DATA**

**General technical data**

Linear Unit	Carriage length Lv [ mm ]	Dynamic load capacity C [ N ]	Dynamic moment			Max. permissible loads					Moved mass [ kg ]	* Max. length Lmax [ mm ]	* Max. stroke [ mm ]
			Mx [ Nm ]	My [ Nm ]	Mz [ Nm ]	Forces		Moments					
						Fpy [ N ]	Fpz [ N ]	Mpx [ Nm ]	Mpy [ Nm ]	Mpz [ Nm ]			
CTV 90 S	35	4620	125	17	34	2000	4540	125	17	34	0,3	750	665
CTV 90 L	100	9240	250	300	300	3990	9090	250	297	130	0,5		600

\* For lengths / stroke over the stated value in the table above please contact us.  
Values for max. stroke are not valid for double carriage.  
(equation of defining the linear unit length for particular size of the linear unit needs to be used).

**i Recommended values of loads:**

All the data of dynamic moments and load capacities stated in the upper table are theoretical without considering any safety factor. The safety factor depends on the application and its requested safety. We recommend a minimum safety factor (fs = 5.0)

**Modulus of elasticity**

$E = 70000 \text{ N / mm}^2$

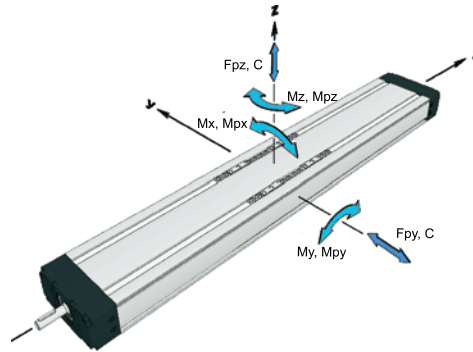

Operating conditions	
Operating temp.	0°C ~ +60°C
Duty cycle	100%

For operating temperature out of the presented range, please contact us.

**General technical data for double carriage**

Linear Unit	Carriage version	Dynamic load capacity C [ N ]	* Dynamic moment			* Forces		Max. permissible loads		
			Mx [ Nm ]	My [ Nm ]	Mz [ Nm ]	Fpy [ N ]	Fpz [ N ]	Mpx [ Nm ]	Mpy [ Nm ]	Mpz [ Nm ]
CTV 90	S2	9240	250	4,6 * A [mm]	4,6 * A [mm]	3990	9090	250	4,5 * A [mm]	2,0 * A [mm]

\* A - Distance between carriages. More info on following pages.

**i** Presented values are for informational purposes only. Exact values can be calculated using our sizing selection tool on Unimotion web site.  
For greater number of carriages please contact us.

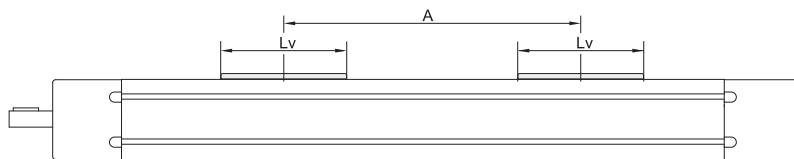

**Ball Screw Drive data**

Linear Unit	Ball screw [ d × l ]	Max. rotational speed [ rev / min ]	1 Max. travel speed [ m / s ]	2 No load torque		Lead constant [ mm / rev ]	3 Max. repeatability precision [ mm ]		Dynamic load capacity BS Ca [ N ]	Max. Axial load Fx [ N ]	Max. drive torque Ma [ Nm ]	4 Min. stroke [ mm ]	1 Max. acceleration [ m/s² ]
				Carriage: S [ Nm ]	Carriage: L [ Nm ]		STANDARD ISO7	ISO5					
CTV 90	12 × 5	5800	0,49	0,07	0,09	5	± 0,02	± 0,01	5000	5000	4,4 without Keyway	30	20
	12 × 10		0,97	0,06	0,08	10	± 0,02	± 0,01	3800	2540	4,5 without Keyway		

1 Max. travel speed depends of the length of the linear unit, see diagram for particular size of the linear unit.  
For travel speed and acceleration over the stated value in the table above or diagrams please contact us.

2 The stated values are for strokes up to 500mm.  
No Load Torque value increases with stroke elongation

3 For the ball nut with the preload of 2% please contact us

4 For minimum stroke below the stated value in the table above please contact us.

**Mass moment inertia of Linear unit**

Linear unit	Carriage version	Ball screw [ d × l ]	Mass moment of inertia [ 10 <sup>-5</sup> kg · m <sup>2</sup> ]		
			Planar moment of inertia I <sub>y</sub> [ cm <sup>4</sup> ]	I <sub>z</sub> [ cm <sup>4</sup> ]	
CTV 90	S	12 × 5	0,32 + 0,002 * Stroke [ mm ]	13,6	102,6
		12 × 10	0,38 + 0,002 * Stroke [ mm ]		
	L	12 × 5	0,43 + 0,002 * Stroke [ mm ]		
		12 × 10	0,53 + 0,002 * Stroke [ mm ]		

**Mass of Linear unit**

Linear unit	Carriage Length L <sub>v</sub> [ mm ]	Mass of Linear unit [ kg ]
CTV 90 S	35	1,6 + 0,006 * Stroke [ mm ]
CTV 90 L	100	2,2 + 0,006 * Stroke [ mm ]

**i** Mass calculation doesn't include mass of motor, reduction gear, switches and clamps.

**Deflection of the linear unit**

**Fixed - fixed mounting**

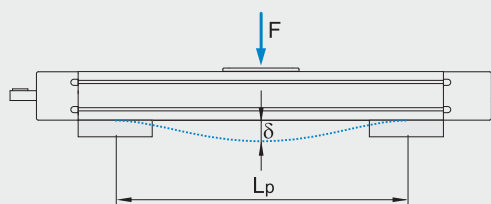

**Fixed - free mounting**

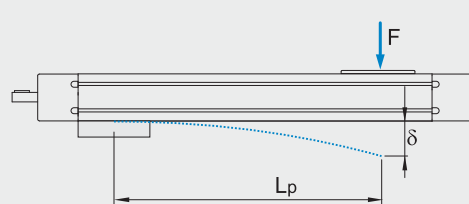

- δ Maximum deflection of the linear unit [mm]
- δ<sub>max</sub> Maximum permissible deflection of the linear unit [mm]
- F Applied force [N]
- L<sub>p</sub> Unsupported profile length [mm]

**i** The maximum permissible deflection δ<sub>max</sub> must not be exceeded. In the case that maximum deflection δ exceeds the maximum permissible deflection δ<sub>max</sub> additional profile supports are needed.

**CTV 90**

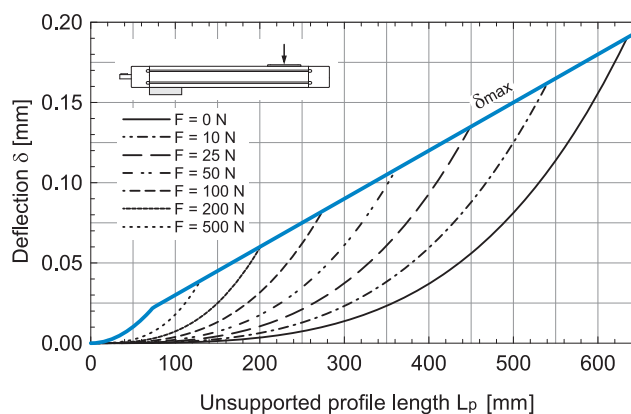
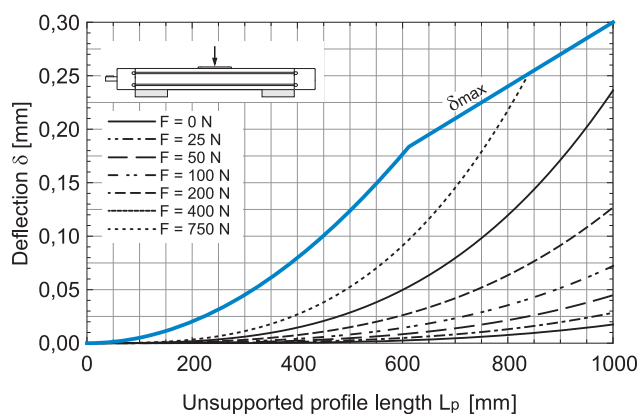



**DIMENSIONS**

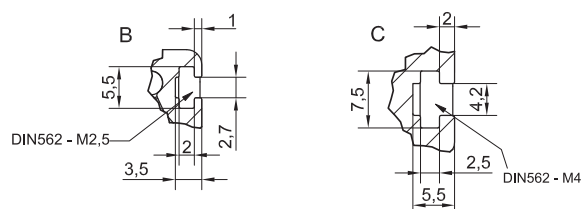
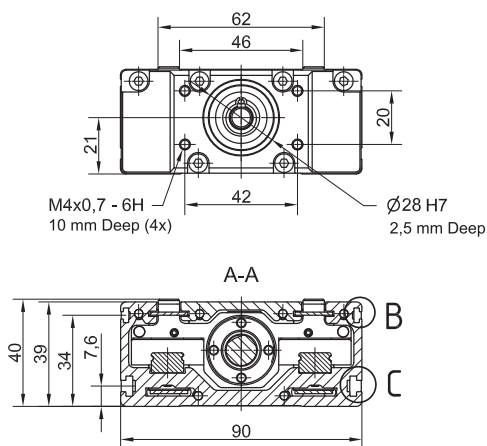

**i** OPTIONAL: TAP / PIN holes available on request.

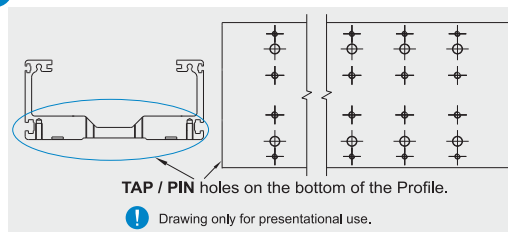

**i** All dimensions in mm; Drawings scales are not equal.

**i** Drawing only for presentational use.

**CONNECTION PLATE**

**CTV 90 L**

**CTV 90 S**

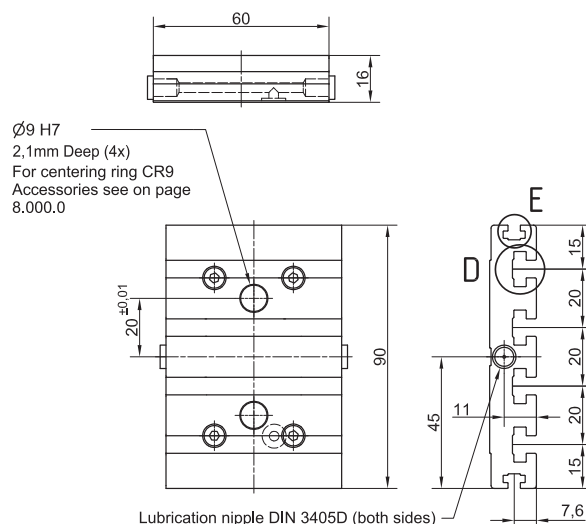
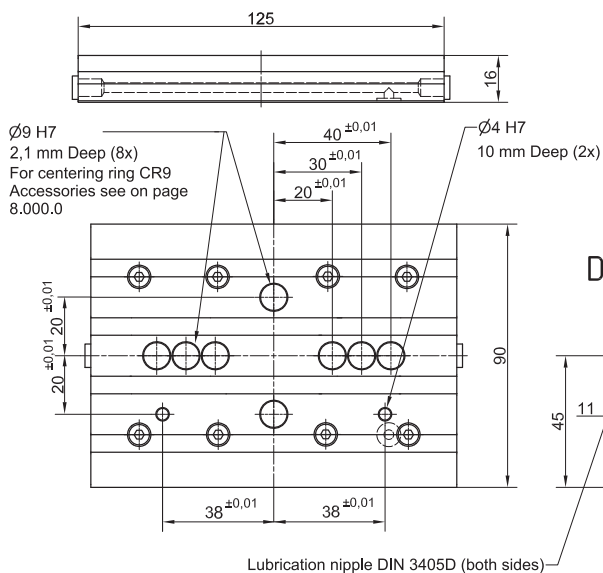

Linear Unit	Plate length [mm]	Weight [kg]	Code
CTV 90 S	60	0,21	46906
CTV 90 L	125	0,44	46907

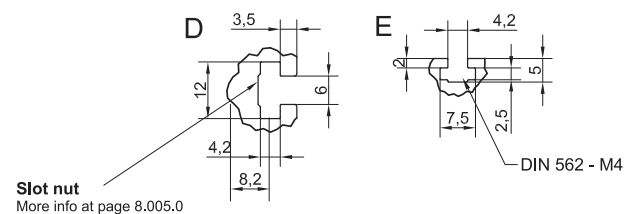

**Slot nut**  
More info at page 8.005.0

**i** Mounting elements for mounting the connection plate on the Linear unit are included.

**Maximum travel speed as a function of the profile length (V<sub>max</sub> - L curves)**

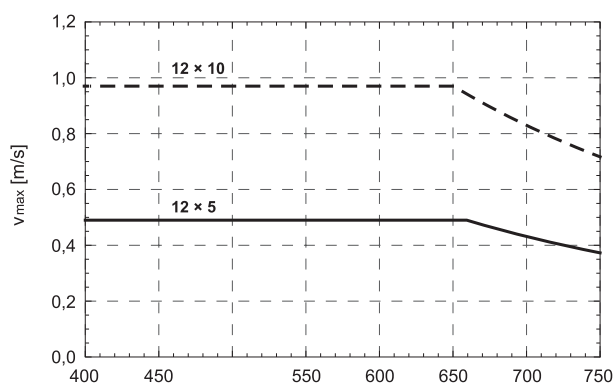

**Mounting the drive**

- by the **MOTOR SIDE DRIVE - MSD** (Page 7.095.0)
- by the **MOTOR ADAPTER WITH COUPLING** (Page 8.020.0)

**i** Available on request.



**TECHNICAL DATA**

**General technical data**

Linear Unit	Carriage length Lv [ mm ]	Dynamic load capacity C [ N ]	Dynamic moment			Max. permissible loads					Moved mass [ kg ]	* Max. length Lmax [ mm ]	* Max. stroke [ mm ]	
			Mx [ Nm ]	My [ Nm ]	Mz [ Nm ]	Forces		Moments						
						Fpy [ N ]	Fpz [ N ]	Mpx [ Nm ]	Mpy [ Nm ]	Mpz [ Nm ]				
CTV 110 S	39	19800	650	118	235	4670	9390	310	90	90	0,63	1500	1410	
CTV 110 L	124	39600	1305	1680	1680	13080	18800	620	800	550	1,36		1325	

\* For lengths / stroke over the stated value in the table above please contact us.  
Values for max. stroke are not valid for double carriage.  
(equation of defining the linear unit length for particular size of the linear unit needs to be used).

**i Recommended values of loads:**

All the data of dynamic moments and load capacities stated in the upper table are theoretical without considering any safety factor. The safety factor depends on the application and its requested safety. We recommend a minimum safety factor (fs = 5.0)

**Modulus of elasticity**

$E = 70000 \text{ N / mm}^2$

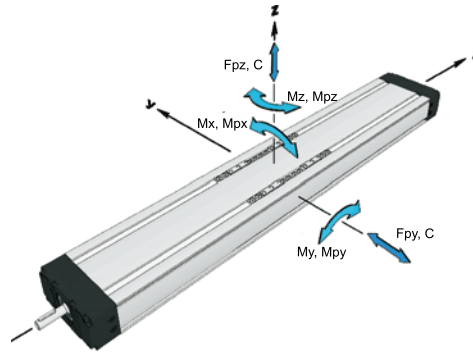

Operating conditions	
Operating temp.	0°C ~ +60°C
Duty cycle	100%

For operating temperature out of the presented range, please contact us.

**General technical data for double carriage**

Linear Unit	Carriage version	Dynamic load capacity C [ N ]	* Dynamic moment			* Forces		Max. permissible loads		
			Mx [ Nm ]	My [ Nm ]	Mz [ Nm ]	Fpy [ N ]	Fpz [ N ]	Mpx [ Nm ]	Mpy [ Nm ]	Mpz [ Nm ]
CTV 110	S2	39600	1300	19,8 * A [mm]	19,8 * A [mm]	12940	18790	620	9,4 * A [mm]	6,5 * A [mm]

\* A - Distance between carriages. More info on following pages.

**i** Presented values are for informational purposes only. Exact values can be calculated using our sizing selection tool on Unimotion web site.  
For greater number of carriages please contact us.

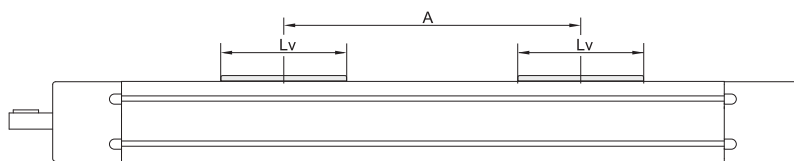

**Ball Screw Drive data**

Linear Unit	Ball screw [ d × l ]	Max. rotational speed [ rev / min ]	1 Max. travel speed [ m / s ]	2 No load torque		Lead constant [ mm / rev ]	3 Max. repeatability precision [ mm ]		Dynamic load capacity BS Ca [ N ]	Max. Axial load Fx [ N ]	Max. drive torque Ma [ Nm ]	4 Min. stroke [ mm ]	1 Max. acceleration [ m/s² ]
				Carriage: S [ Nm ]	Carriage: L [ Nm ]		STANDARD ISO7	ISO5					
CTV 110	16 × 5	4200	0,35	0,11	0,13	5	± 0,02	± 0,01	13150	8700	5,5 with Keyway 7,7 without Keyway	40	20
	16 × 10		0,70	0,12	0,16	10	± 0,02	± 0,01	11550	6730	5,5 with Keyway 11,9 without Keyway		
	16 × 16		1,12	0,14	0,18	16	± 0,02	± 0,01	8170	4200			

1 Max. travel speed depends of the length of the linear unit, see diagram for particular size of the linear unit.  
For travel speed and acceleration over the stated value in the table above or diagrams please contact us.

2 The stated values are for strokes up to 500mm.  
No Load Torque value increases with stroke elongation

3 For the ball nut with the preload of 2% please contact us

4 For minimum stroke below the stated value in the table above please contact us.

**Mass moment inertia of Linear unit**

Linear unit	Carriage version	Ball screw [ d × l ]	Mass moment of inertia [ 10 <sup>-5</sup> kg · m <sup>2</sup> ]	Planar moment of inertia	
				I <sub>y</sub> [ cm <sup>4</sup> ]	I <sub>z</sub> [ cm <sup>4</sup> ]
CTV 110	S	16 × 5	0,70 + 0,005 · Stroke [ mm ]	29,1	196,0
		16 × 10	0,82 + 0,005 · Stroke [ mm ]		
		16 × 16	1,07 + 0,005 · Stroke [ mm ]		
	L	16 × 5	1,19 + 0,005 · Stroke [ mm ]		
		16 × 10	1,45 + 0,005 · Stroke [ mm ]		
		16 × 16	1,99 + 0,005 · Stroke [ mm ]		

**Mass of Linear unit**

Linear unit	Carriage Length L <sub>v</sub> [ mm ]	Mass of Linear unit [ kg ]
CTV 110 S	39	3,3 + 0,008 · Stroke [ mm ]
CTV 110 L	124	4,6 + 0,008 · Stroke [ mm ]

**i** Mass calculation doesn't include mass of motor, reduction gear, switches and clamps.

**Deflection of the linear unit**

**Fixed - fixed mounting**

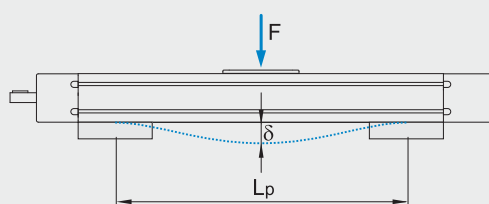

**Fixed - free mounting**

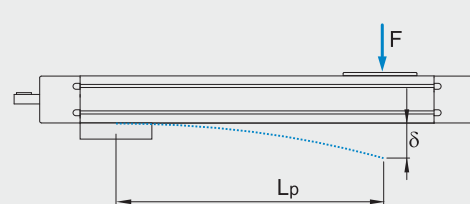

- δ Maximum deflection of the linear unit [mm]
- δ<sub>max</sub> Maximum permissible deflection of the linear unit [mm]
- F Applied force [N]
- L<sub>p</sub> Unsupported profile length [mm]

**i** The maximum permissible deflection δ<sub>max</sub> must not be exceeded. In the case that maximum deflection δ exceeds the maximum permissible deflection δ<sub>max</sub> additional profile supports are needed.

**CTV 110**

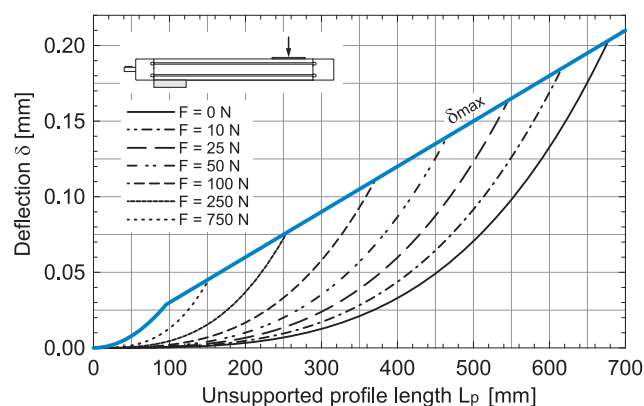
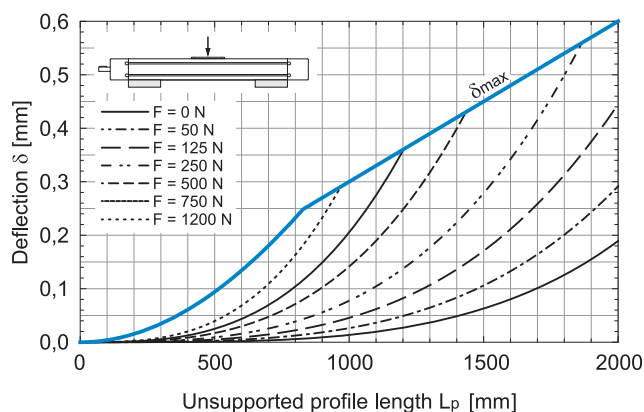

**DIMENSIONS**

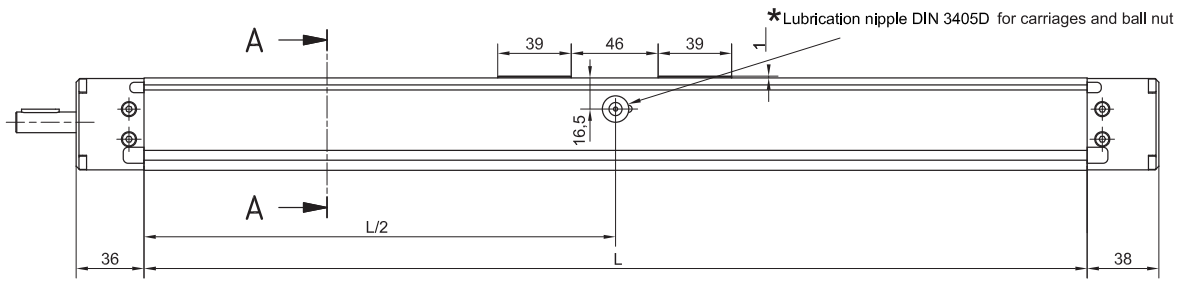

**i** Linear Unit doesn't include any safety stroke.  
Absolute stroke = Effective stroke + 2 x Safety stroke

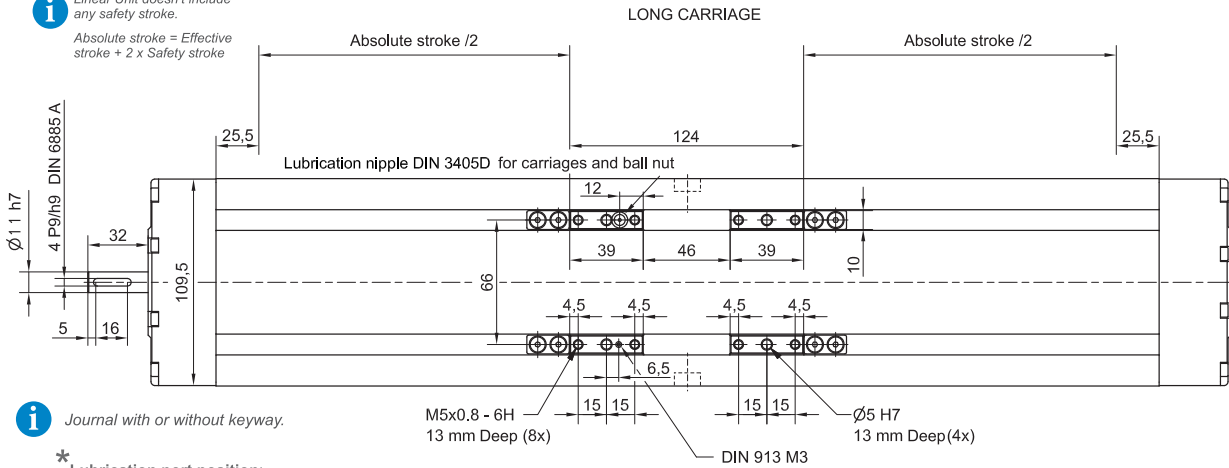

**i** Journal with or without keyway.

\* Lubrication port position:  
Long carriage: L/2  
Short carriage: L/2 - 39 mm

**i** All dimensions in mm.  
Drawings scales are not equal.

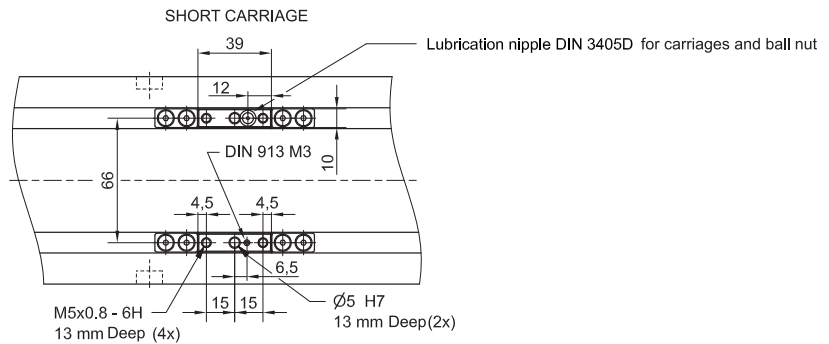

**Defining of the linear unit length**

**L = Effective stroke + 2 × Safety stroke + Lv + 51 mm**

**Ltotal = L + 74 mm**

Left side (L)

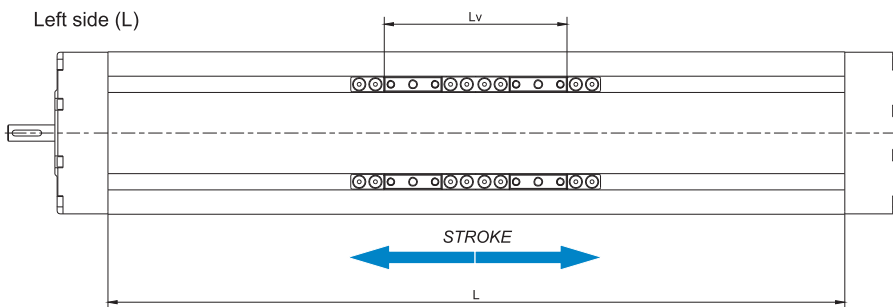

Right side (R)

Lv - Long carriage = 124 mm  
Lv - Short carriage = 39 mm

**L = Effective stroke + 2 × Safety stroke + A + 90 mm**  
**Ltotal = L + 74 mm** } **A ≥ 85 mm** **!**

**Double-Carriage**

**i** Only with **short carriage** version.

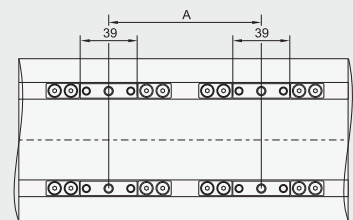

**i** For ordering code please contact us.

**DIMENSIONS**

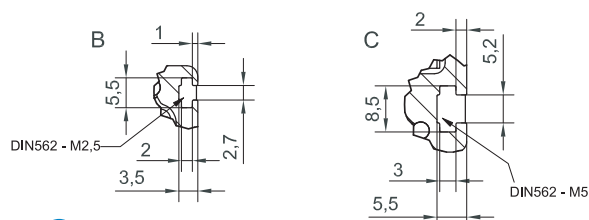
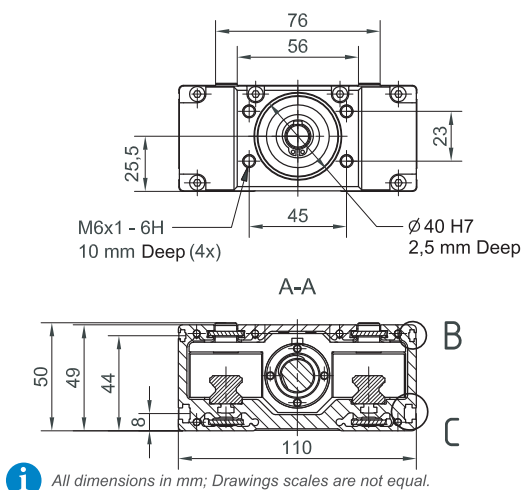

**i** **OPTIONAL: TAP / PIN** holes available on request.

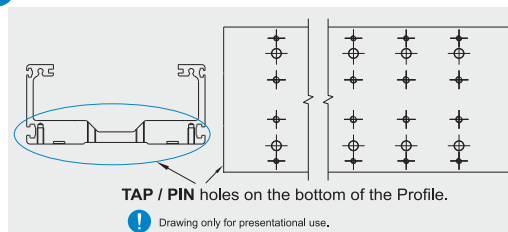

**CONNECTION PLATE**

**CTV 110 L**

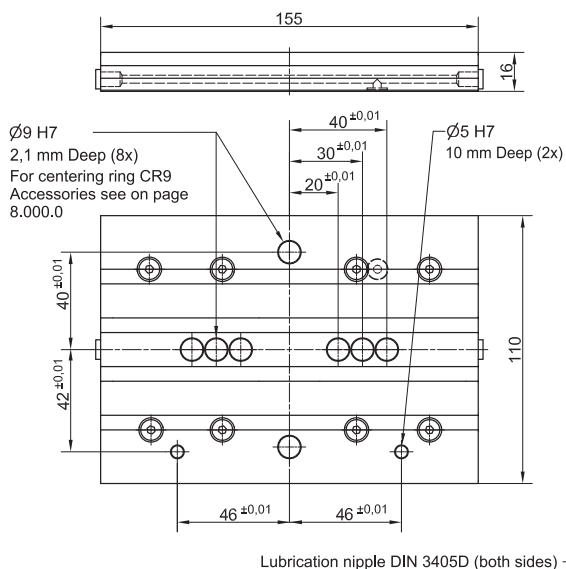

**CTV 110 S**

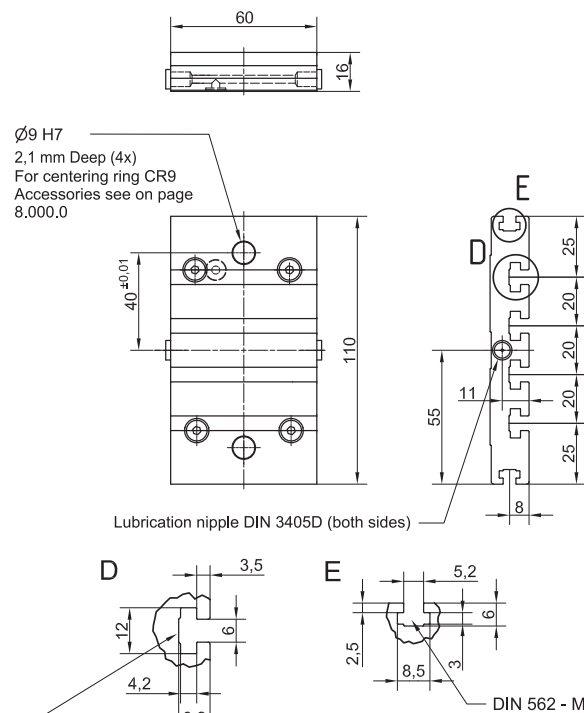

**Slot nut**  
More info at page 8.005.0

Linear Unit	Plate length [mm]	Weight [kg]	Code
CTV 110 S	60	0,37	48348
CTV 110 L	155	0,74	48349

**i** Mounting elements for mounting the connection plate on the Linear unit are included.

**Mounting the drive**

- by the **MOTOR SIDE DRIVE - MSD** (Page 7.095.0)
- by the **MOTOR ADAPTER WITH COUPLING** (Page 8.020.0)

**i** Available on request.

**Maximum travel speed as a function of the profile length (V<sub>max</sub> - L curves)**

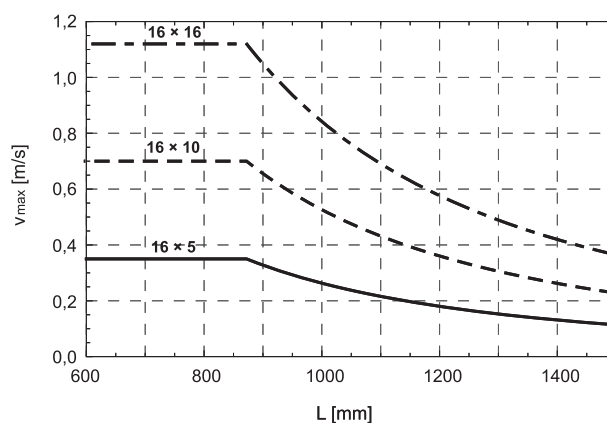

**TECHNICAL DATA**

**General technical data**

Linear Unit	Carriage length Lv [ mm ]	Dynamic load capacity C [ N ]	Dynamic moment			Max. permissible loads					Moved mass [ kg ]	* Max. length Lmax [ mm ]	* Max. stroke [ mm ]
			Mx [ Nm ]	My [ Nm ]	Mz [ Nm ]	Forces		Moments					
						Fpy [ N ]	Fpz [ N ]	Mpx [ Nm ]	Mpy [ Nm ]	Mpz [ Nm ]			
CTV 145 S	49	34200	1500	260	520	8930	15320	674	260	180	1,19	1800	1690
CTV 145 L	149	68400	3005	3420	3420	17870	30680	1350	1700	893	2,61		1590

\* For lengths / stroke over the stated value in the table above please contact us.  
Values for max. stroke are not valid for double carriage.  
(equation of defining the linear unit length for particular size of the linear unit needs to be used).

**i Recommended values of loads:**

All the data of dynamic moments and load capacities stated in the upper table are theoretical without considering any safety factor. The safety factor depends on the application and its requested safety. We recommend a minimum safety factor (fs = 5.0)

**Modulus of elasticity**

$E = 70000 \text{ N / mm}^2$

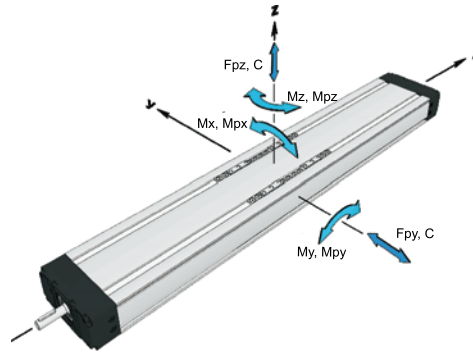

Operating conditions	
Operating temp.	0°C ~ +60°C
Duty cycle	100%

For operating temperature out of the presented range, please contact us.

**General technical data for double carriage**

Linear Unit	Carriage version	Dynamic load capacity C [ N ]	* Dynamic moment			* Forces		Max. permissible loads		
			Mx [ Nm ]	My [ Nm ]	Mz [ Nm ]	Fpy [ N ]	Fpz [ N ]	Mpx [ Nm ]	Mpy [ Nm ]	Mpz [ Nm ]
CTV 145	S2	68400	3000	34,2 * A [mm]	34,2 * A [mm]	17870	30640	1350	15,3 * A [mm]	8,9 * A [mm]

\*A - Distance between carriages. More info on following pages.

**i** Presented values are for informational purposes only. Exact values can be calculated using our sizing selection tool on Unimotion web site.  
For greater number of carriages please contact us.

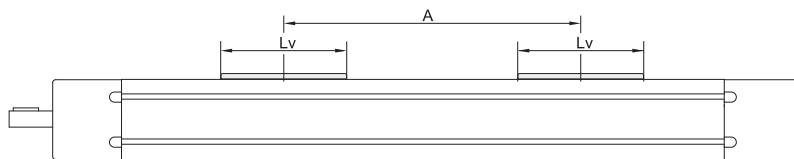

**Ball Screw Drive data**

Linear Unit	Ball screw [ d × l ]	Max. rotational speed [ rev / min ]	1 Max. travel speed [ m / s ]	2 No load torque		Lead constant [ mm / rev ]	3 Max. repeatability precision [ mm ]		Dynamic load capacity BS Ca [ N ]	Max. Axial load Fx [ N ]	Max. drive torque Ma [ Nm ]	4 Min. stroke [ mm ]	1 Max. acceleration [ m/s² ]	
				Carriage: S [ Nm ]	Carriage: L [ Nm ]		STANDARD	ISO7						ISO5
CTV 145	20 × 5	3300	0,28	0,28	0,3	5	± 0,02	± 0,01	14800	14800	11,9 with Keyway 13,0 without Keyway	55	20	
	20 × 10			0,55	0,26	0,28	10	± 0,02						± 0,01
	20 × 20			1,10	0,24	0,28	20	± 0,02						± 0,01
	20 × 50	3000	2,50	0,58	0,6	50	± 0,02	± 0,01	13000	2770	11,9 with Keyway 24,5 without Keyway			

1 Max. travel speed depends of the length of the linear unit, see diagram for particular size of the linear unit.  
For travel speed and acceleration over the stated value in the table above or diagrams please contact us.

2 The stated values are for strokes up to 500mm.  
No Load Torque value increases with stroke elongation

3 For the ball nut with the preload of 2% please contact us

4 For minimum stroke below the stated value in the table above please contact us.

**Mass moment inertia of Linear unit**

Linear unit	Carriage version	Ball screw [ d × l ]	Mass moment of inertia [ 10 <sup>-5</sup> kg · m <sup>2</sup> ]	Planar moment of inertia	
				I <sub>y</sub> [ cm <sup>4</sup> ]	I <sub>z</sub> [ cm <sup>4</sup> ]
CTV 145	S	20 × 5	3,04 + 0,013 · Stroke [ mm ]	85,3	682,3
		20 × 10	3,27 + 0,013 · Stroke [ mm ]		
		20 × 20	4,17 + 0,013 · Stroke [ mm ]		
		20 × 50	10,50 + 0,013 · Stroke [ mm ]		
	L	20 × 5	4,43 + 0,013 · Stroke [ mm ]		
		20 × 10	4,92 + 0,013 · Stroke [ mm ]		
		20 × 20	6,91 + 0,013 · Stroke [ mm ]		
		20 × 50	20,79 + 0,013 · Stroke [ mm ]		

**Mass of Linear unit**

Linear unit	Carriage Length L <sub>v</sub> [ mm ]	Mass of Linear unit [ kg ]
CTV 145 S	49	5,7 + 0,015 · Stroke [ mm ]
CTV 145 L	149	8,4 + 0,015 · Stroke [ mm ]

**i** Mass calculation doesn't include mass of motor, reduction gear, switches and clamps.

**Deflection of the linear unit**

**Fixed - fixed mounting**

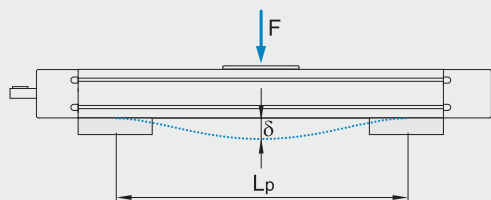

**Fixed - free mounting**

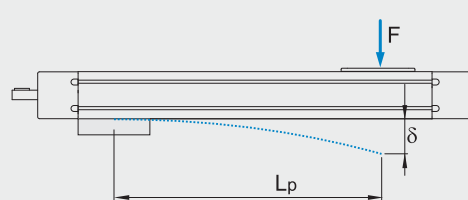

- δ Maximum deflection of the linear unit [mm]
- δ<sub>max</sub> Maximum permissible deflection of the linear unit [mm]
- F Applied force [N]
- L<sub>p</sub> Unsupported profile length [mm]

**i** The maximum permissible deflection δ<sub>max</sub> must not be exceeded. In the case that maximum deflection δ exceeds the maximum permissible deflection δ<sub>max</sub> additional profile supports are needed.

**CTV 145**

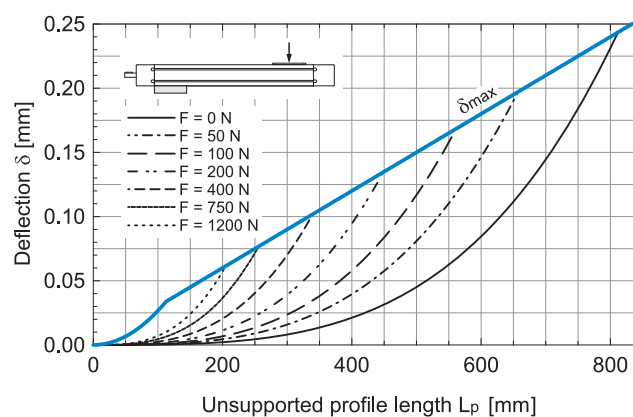
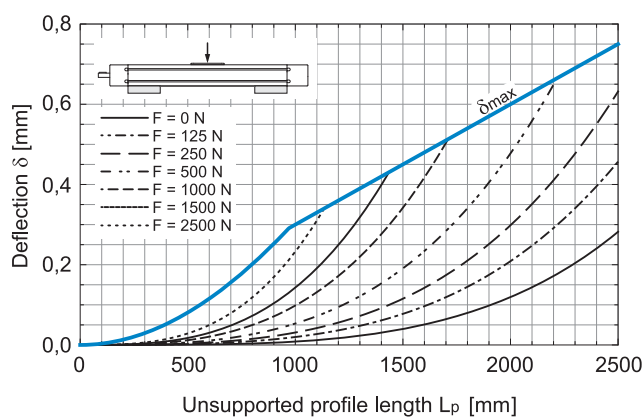



**DIMENSIONS**

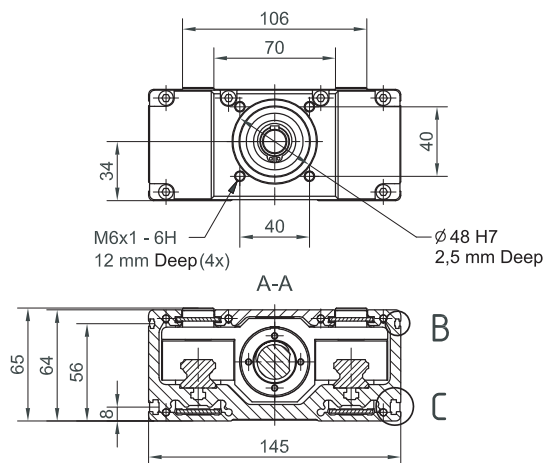

**i** All dimensions in mm; Drawings scales are not equal.

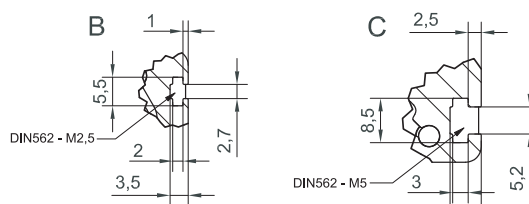

**i** **OPTIONAL: TAP / PIN** holes available on request.

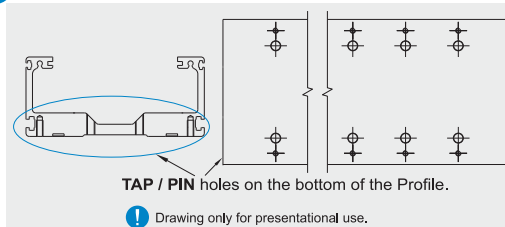

**i** Drawing only for presentational use.

**CONNECTION PLATE**

**CTV 145 L**

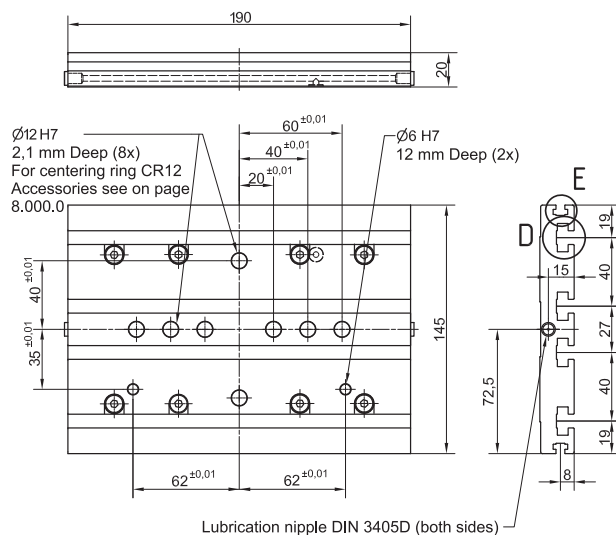

**CTV 145 S**

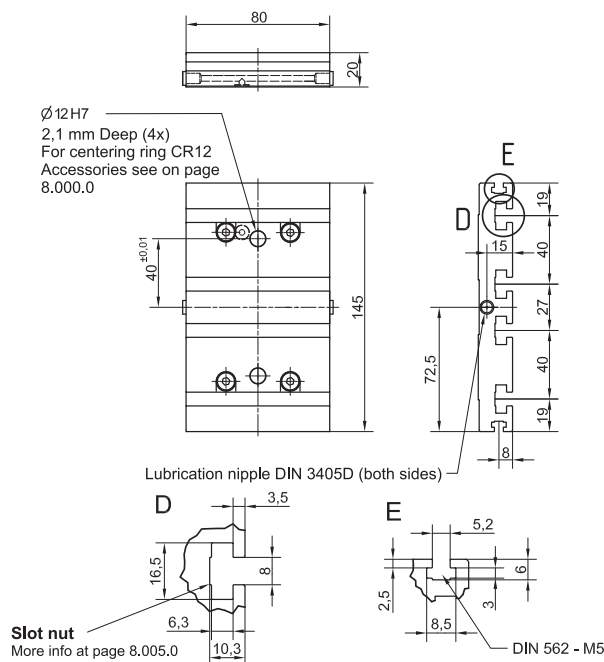

Linear Unit	Plate length [mm]	Weight [kg]	Code
CTV 145 S	80	0,78	48351
CTV 145 L	190	1,54	48350

**i** Mounting elements for mounting the connection plate on the Linear unit are included.

**Mounting the drive**

- by the **MOTOR SIDE DRIVE - MSD** (Page 7.095.0)
- by the **MOTOR ADAPTER WITH COUPLING** (Page 8.020.0)

**i** Available on request.

**Maximum travel speed as a function of the profile length ( $V_{max}$  - L curves)**

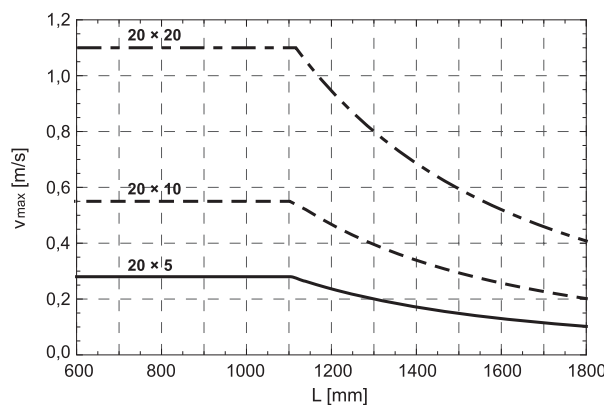
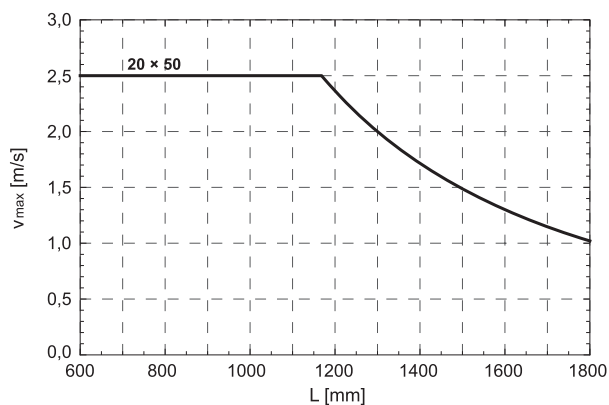



**TECHNICAL DATA**

**General technical data**

Linear Unit	Carriage length Lv [ mm ]	Dynamic load capacity C [ N ]	Dynamic moment			Max. permissible loads					Moved mass [ kg ]	* Max. length Lmax [ mm ]	* Max. stroke [ mm ]
			Mx [ Nm ]	My [ Nm ]	Mz [ Nm ]	Forces		Moments					
						Fpy [ N ]	Fpz [ N ]	Mpx [ Nm ]	Mpy [ Nm ]	Mpz [ Nm ]			
CTV 200 S	80	49600	3220	450	900	10000	24610	1600	450	308	3,11	2200	2000
CTV 200 L	255	99200	6445	8680	8680	20000	51540	3350	4550	1750	6,21		1825

\* For lengths / stroke over the stated value in the table above please contact us.  
Values for max. stroke are not valid for double carriage.  
(equation of defining the linear unit length for particular size of the linear unit needs to be used).

**i Recommended values of loads:**

All the data of dynamic moments and load capacities stated in the upper table are theoretical without considering any safety factor. The safety factor depends on the application and its requested safety. We recommend a minimum safety factor (fs = 5.0)

**Modulus of elasticity**

$E = 70000 \text{ N / mm}^2$

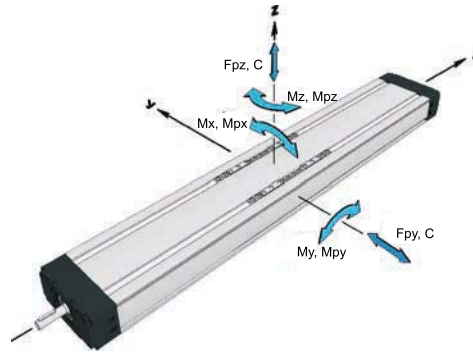

Operating conditions	
Operating temp.	0°C ~ +60°C
Duty cycle	100%

For operating temperature out of the presented range, please contact us.

**General technical data for double carriage**

Linear Unit	Carriage version	Dynamic load capacity C [ N ]	* Dynamic moment			* Forces		Max. permissible loads		
			Mx [ Nm ]	My [ Nm ]	Mz [ Nm ]	Fpy [ N ]	Fpz [ N ]	Mpx [ Nm ]	Mpy [ Nm ]	Mpz [ Nm ]
CTV 200	S2	99200	6440	49,6 * A [mm]	49,6 * A [mm]	20000	49230	3200	24,6 * A [mm]	10,0 * A [mm]

\*A - Distance between carriages. More info on following pages.

**i** Presented values are for informational purposes only. Exact values can be calculated using our sizing selection tool on Unimotion web site.  
For grater number of carriages please contact us.

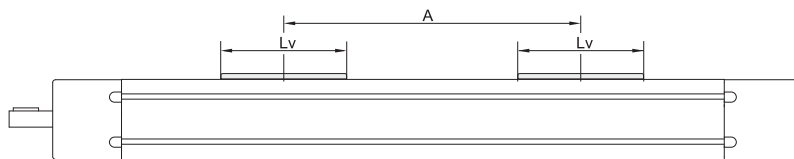

**Ball Screw Drive data**

Linear Unit	Ball screw [ d × l ]	Max. rotational speed [ rev / min ]	1 Max. travel speed [ m / s ]	2 No load torque		Lead constant [ mm / rev ]	3 Max. repeatability precision [ mm ]		Dynamic load capacity BS Ca [ N ]	Max. Axial load Fx [ N ]	Max. drive torque Ma [ Nm ]	4 Min. stroke [ mm ]	1 Max. acceleration [ m/s² ]
				Carriage: S [ Nm ]	Carriage: L [ Nm ]		STANDARD	ISO5					
CTV 200	32 × 5	2150	0,18	0,45	0,55	5	± 0,02	± 0,01	18850	18850	16,7 with Keyway 16,7 without Keyway	65	20
	32 × 10			0,50	0,60	10	± 0,02	± 0,01					
	32 × 20	3000	1,00	0,55	0,65	20	± 0,02	± 0,01	29700	14800	27,3 with Keyway 52,3 without Keyway		
	32 × 32			0,60	0,70	32	± 0,02	± 0,01					

1 Max. travel speed depends of the length of the linear unit, see diagram for particular size of the linear unit.  
For travel speed and acceleration over the stated value in the table above or diagrams please contact us.

2 The stated values are for strokes up to 500mm.  
No Load Torque value increases with stroke elongation

3 For the ball nut with the preload of 2% please contact us

4 For minimum stroke below the stated value in the table above please contact us.

Mass moment inertia of Linear unit

Linear unit	Carriage version	Ball screw [ d × l ]	Mass moment of inertia [ 10 <sup>-5</sup> kg · m <sup>2</sup> ]	Planar moment of inertia	
				I <sub>y</sub> [ cm <sup>4</sup> ]	I <sub>z</sub> [ cm <sup>4</sup> ]
CTV 200	S	32 × 5	21,17 + 0,069 · Stroke [ mm ]	417,4	3007,3
		32 × 10	21,76 + 0,069 · Stroke [ mm ]		
		32 × 20	24,12 + 0,069 · Stroke [ mm ]		
		32 × 32	29,04 + 0,069 · Stroke [ mm ]		
	L	32 × 5	33,41 + 0,069 · Stroke [ mm ]		
		32 × 10	34,59 + 0,069 · Stroke [ mm ]		
		32 × 20	39,31 + 0,069 · Stroke [ mm ]		
		32 × 32	49,12 + 0,069 · Stroke [ mm ]		

Mass of Linear unit

Linear unit	Carriage Length L <sub>v</sub> [ mm ]	Mass of Linear unit [ kg ]
CTV 200 S	80	15,4 + 0,031 · Stroke [ mm ]
CTV 200 L	255	23,8 + 0,031 · Stroke [ mm ]

**i** Mass calculation doesn't include mass of motor, reduction gear, switches and clamps.

Deflection of the linear unit

Fixed - fixed mounting

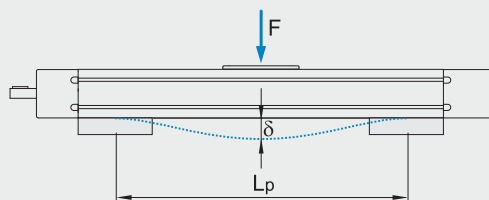

Fixed - free mounting

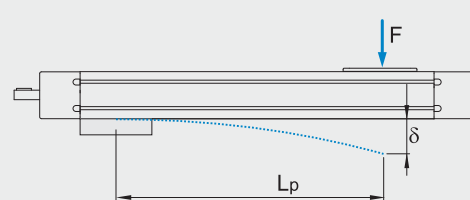

- δ Maximum deflection of the linear unit [mm]
- δ<sub>max</sub> Maximum permissible deflection of the linear unit [mm]
- F Applied force [N]
- L<sub>p</sub> Unsupported profile length [mm]

**i** The maximum permissible deflection δ<sub>max</sub> must not be exceeded. In the case that maximum deflection δ exceeds the maximum permissible deflection δ<sub>max</sub> additional profile supports are needed.

CTV 200

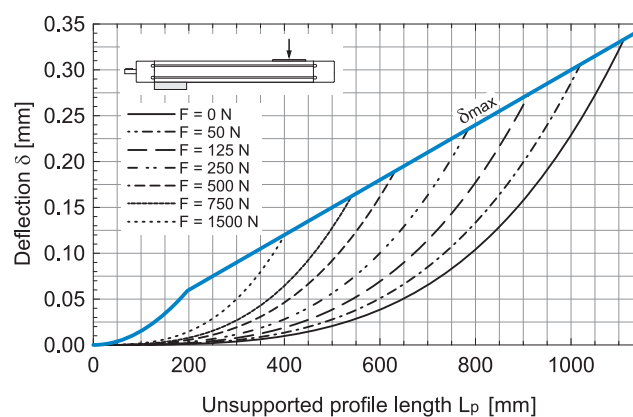
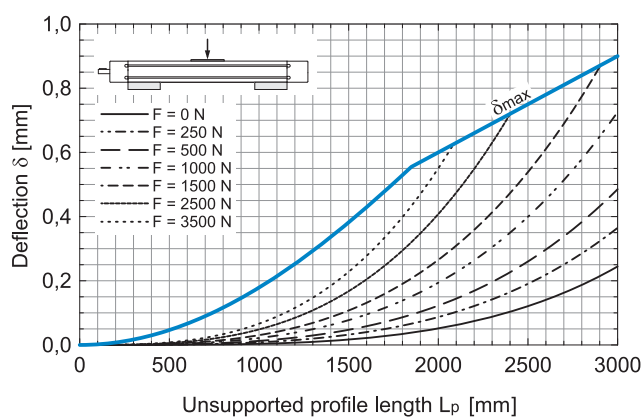

**DIMENSIONS**

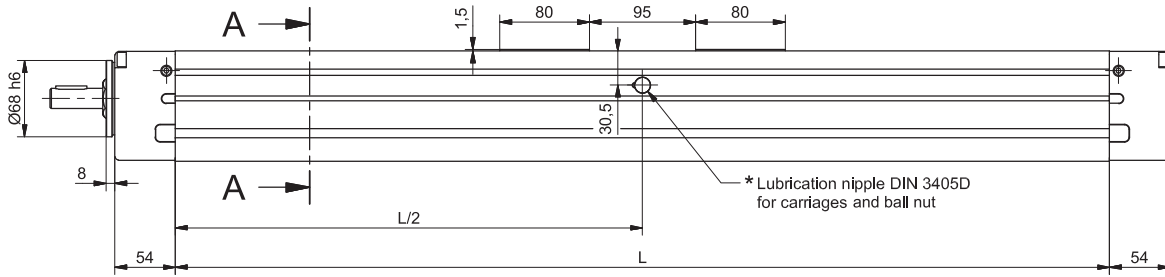

**i** Linear Unit doesn't include any safety stroke.  
Absolute stroke = Effective stroke + 2 x Safety stroke

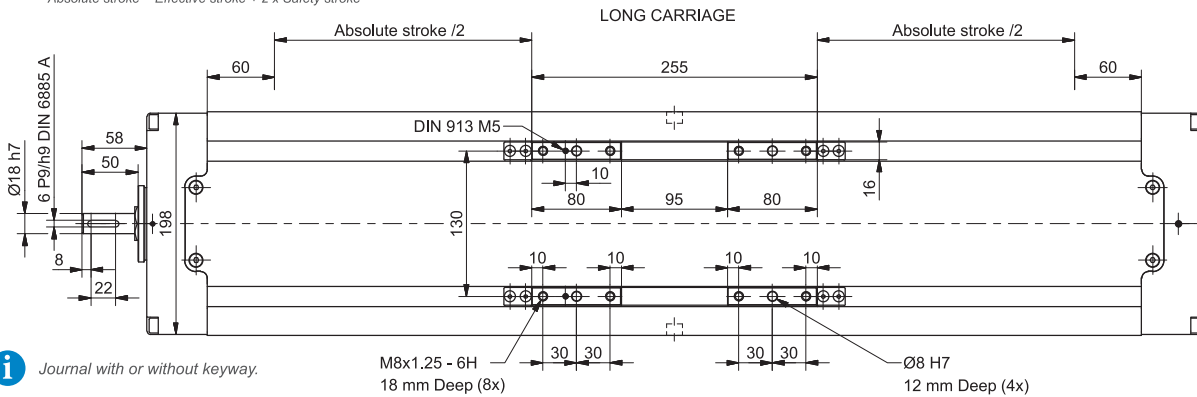

**i** All dimensions in mm.  
Drawings scales are not equal.

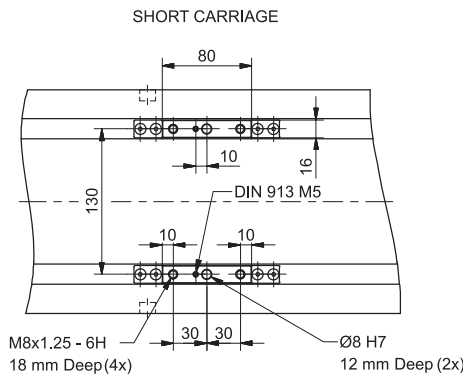

**Defining of the linear unit length**

**$L = \text{Effective stroke} + 2 \times \text{Safety stroke} + L_v + 120 \text{ mm}$**

**$L_{\text{total}} = L + 108 \text{ mm}$**

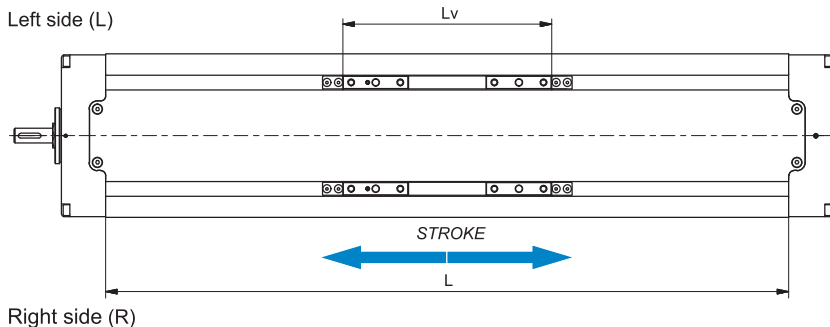

**$L_v$  - Long carriage = 255 mm**  
 **$L_v$  - Short carriage = 80 mm**

**$L = \text{Effective stroke} + 2 \times \text{Safety stroke} + A + 200 \text{ mm}$**   
 **$L_{\text{total}} = L + 108 \text{ mm}$**

**Double-Carriage**

**i** Only with *short carriage* version.

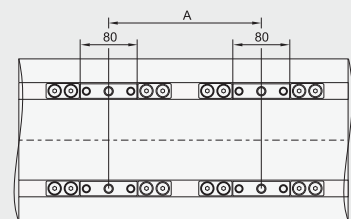

**i** For ordering code please contact us.

**$A \geq 130 \text{ mm}$**   
**\* $A \geq 195 \text{ mm}$**  **!**

\* In case of using the connection plates.

**DIMENSIONS**

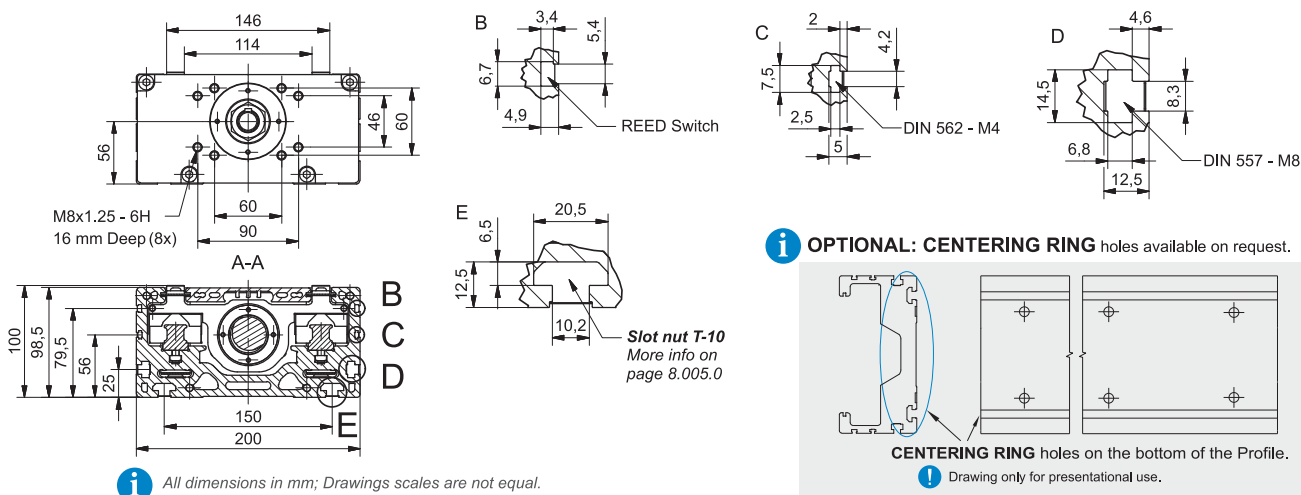

**CONNECTION PLATE**

**CTV 200 L**

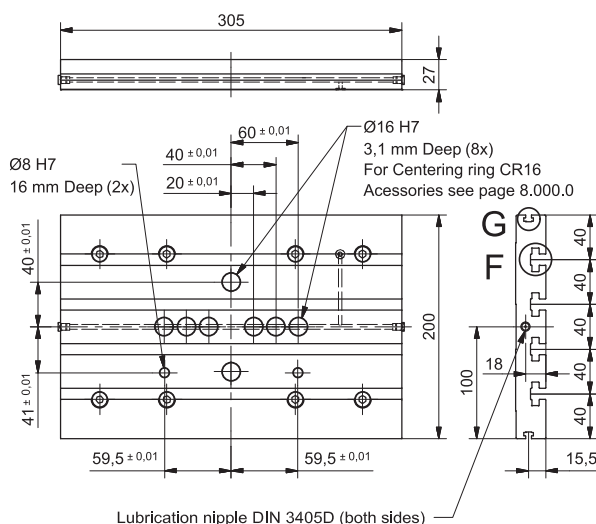

**CTV 200 S**

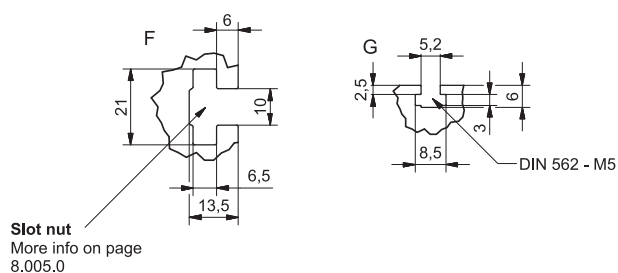
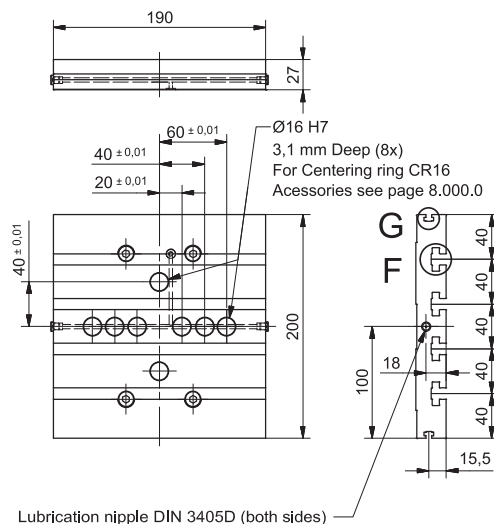

Linear Unit	Plate length [mm]	Weight [kg]	Code
CTV 200 S	190	2,32	66669
CTV 200 L	305	3,75	66657

**i** Mounting elements for mounting the connection plate on the Linear unit are included.  
Please consider our advice in our Maintenance- and assembly instructions

**Mounting the drive**

- by the **MOTOR SIDE DRIVE - MSD** (Page 7.095.0)
- by the **MOTOR ADAPTER WITH COUPLING** (Page 8.020.0)

**i** Available on request.

**Maximum travel speed as a function of the profile length (V<sub>max</sub> - L curves)**

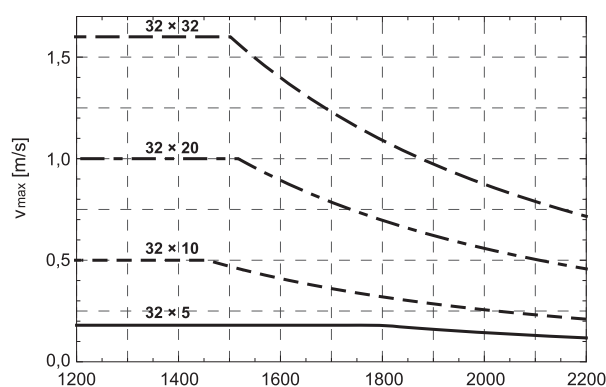

# CTV - MTV MOTOR SIDE DRIVE

## LINEAR UNITS

### STRUCTURAL DESIGN

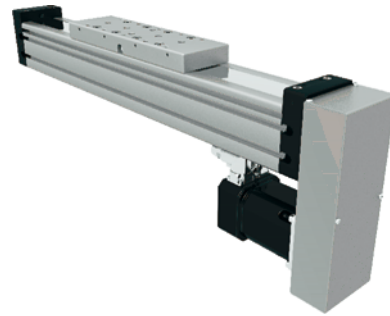
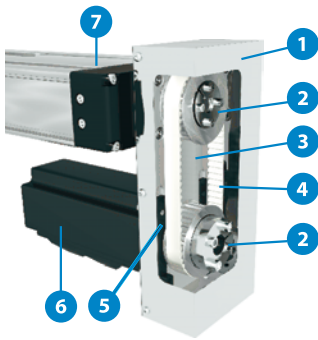

- 1 - Cover
- 2 - Attachment of pulley with clamping set
- 3 - Anodized aluminium housing
- 4 - Toothed belt
- 5 - Belt tensioning system (elongation and frequency of belt span provided with delivery of unit)
- 6 - Motor
- 7 - Linear unit - CTV / MTV

**i** The linear unit must be executed with drive journal without keyway, so that the MSD belt drive can be mounted on it.

#### Possible installation positions of MSD

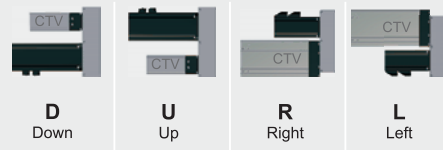

### DIMENSIONS AND TECHNICAL DATA

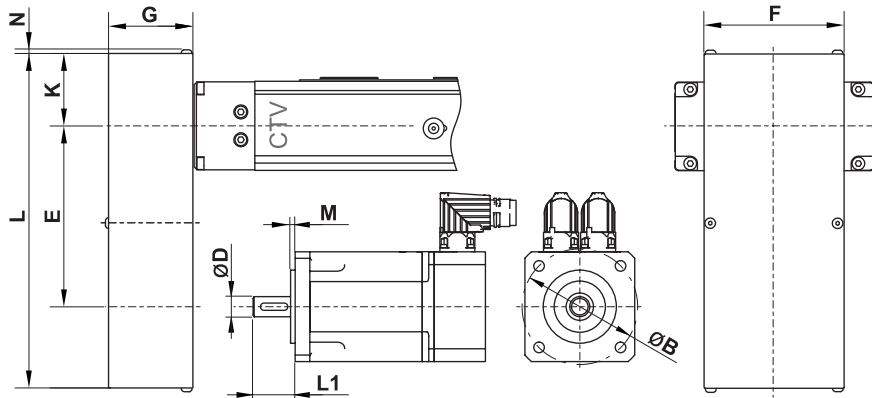

#### Clamping set

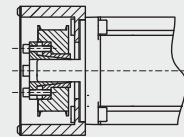

#### Keyway

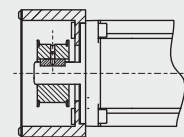

Linear Unit	Type	Gear ratio	Max. drive torque (linear unit) [ Nm ]	** Max. radial load on shaft [ N ]	Mass moment of inertia [ 10 <sup>-6</sup> kg * m <sup>2</sup> ]	Mass [ kg ]	Motor size limits [ mm ]						Dimensions [ mm ]						
							ØB max	* M max	L1		ØD max		E	F	G	K	L	N	
									Clamping set min	Keyway	max	Clamping set max	Keyway						
CTV 90	T1	i=1	2,7	90	79	0,88	70	4	22	25	39	14	22	100	70	41	31	179	2
		i=1,5	2,7	90	48	0,74			/			14	102						
CTV 110 MTV 65	T1	i=1	5	175	72	0,90	70	4	22	25	39	14	22	100	70	41	31	179	2
		i=1,5	5	175	41	0,80			/			14	112						
CTV 110 MTV 65	T2	i=1	9	245	206	1,51	100	4	24	30	49	18	30	145	90	51	43	250	2
		i=1,5	11	235	335	1,53			14			139							
CTV 145 MTV 80	T1	i=1	13	350	207	1,52	100	4	24	30	49	18	30	145	90	51	43	250	2
		i=1,5	19	410	335	1,64			14			180							
CTV 145 MTV 80	T2	i=1	19	410	551	3,30	120	4	30	35	59	22	40	160	120	61	56	297	2,5
		i=2	24	375	860	2,93			14			32	158						
CTV 200 MTV 110	ON REQUEST																		

\*For a bigger value an additional adapter plate is used.

(max. drive speed: 3000 1/min; No load torque: approx. 0,5 Nm)

\*\*This is the load which is linearly dependent on the max. drive torque and is generated by the correct pretension of the belt. This load needs to be reduced in accordance with the capabilities of the motor.

### HOW TO ORDER

**MSD - CTV 110 - T2 - 1,5 - MSM040B**

Motor Side Drive:

Linear Unit series :

CTV / MTV

Type :

Motor type :

According to customer's drawing

Gear ratio :

**MTJ, MRJ, MTV  
MTJ ECO**

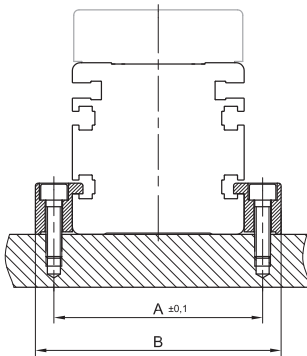

**CTV, CTJ**

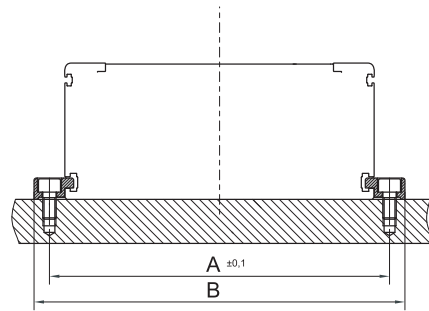

**General**

The linear units are mounted by using fixtures which are placed in the slot on the side of the profile.

**i** Linear Unit must be mounted by the aluminium profile!

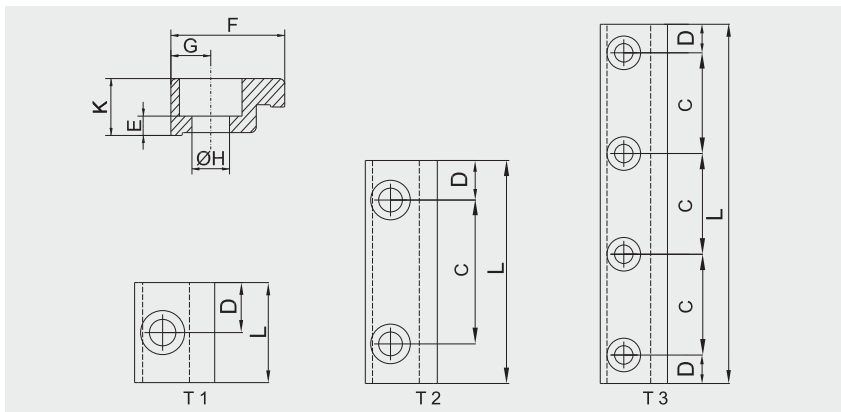

Linear Unit	Type	Dimensions [ mm ]										Screw	Countersink for	Weight [ kg ]	Code
		A	B	C	D	L	E	F	G	ØH	K				
MTJ, MRJ 40	T 2	50	64,4	40	7,5	55	2,5	15	7,2	5,5	8	M5	DIN 912	0,014	37139
MTJ, MRJ, MTV 65	T 2	78	93	40	10	60	11,5	20	7,5	6,5	20	M6	DIN 912	0,054	37129
MTJ, MRJ, MTV 80	T 2	93	108	40	10	60	11,5	20	7,5	6,5	20	M6	DIN 912	0,054	37129
MTJ, MRJ, MTV 110	T 2	130	150	40	10	60	18	30	10	8,5	27	M8	DIN 912	0,082	44375
MTJ ECO 40	T 2	52	66	40	7,5	55	14,5	20	7	5,5	20	M5	DIN 912	0,035	40728
CTV, CTJ 90	T 1	102	112	/	12,5	25	4,5	15	5	4,5	9	M4	DIN 912	0,01	46994
CTV, CTJ 90	T 2	102	112	40	11	62	4,5	15	5	4,5	9	M4	DIN 912	0,02	48636
CTV, CTJ 90	T 3	102	112	20	8,5	77	4,5	15	5	4,5	9	M4	DIN 912	0,025	47163
CTV, CTJ 90	T3	102	112	25	6	87	4,5	15	5	4,5	9	M4	DIN 912	0,028	55261
CTV, CTJ 90	T 3	102	112	30	8,5	107	4,5	15	5	4,5	9	M4	DIN 912	0,031	55638
CTV, CTJ 110	T 1	126	140	/	12,5	25	3,4	20	7	6,6	10	M6	DIN 912	0,01	48642
CTV, CTJ 110	T 2	126	140	40	11	62	3,4	20	7	6,6	10	M6	DIN 912	0,03	48643
CTV, CTJ 110	T 3	126	140	20	8,5	77	4,5	20	7	5,5	10	M5	DIN 912	0,03	48640
CTV, CTJ 110	T 3	126	140	30	8,5	107	4,5	20	7	5,5	10	M5	DIN 912	0,045	46995
CTV, CTJ 110	T3	126	140	40	11	142	3,4	20	7	6,6	10	M6	DIN 912	0,056	55260
CTV, CTJ 145	T 1	161	175	/	12,5	25	3,4	20	7	6,6	10	M6	DIN 912	0,01	48642
CTV, CTJ 145	T 2	161	175	40	11	62	3,4	20	7	6,6	10	M6	DIN 912	0,03	48643
CTV, CTJ 145	T 3	161	175	20	8,5	77	4,5	20	7	5,5	10	M5	DIN 912	0,03	48640
CTV, CTJ 145	T 3	161	175	30	8,5	107	4,5	20	7	5,5	10	M5	DIN 912	0,045	46995
CTV, CTJ 145	T 3	161	175	40	11	142	3,4	20	7	6,6	10	M6	DIN 912	0,056	55260
CTV, CTJ 200	T 2	222	240	40	19	78	14,8	29	9	8,5	27,5	M8	DIN 912	0,110	53049
CTV, CTJ 200	T 2	222	240	50	19	88	14,8	29	9	8,5	27,5	M8	DIN 912	0,120	53050
CTV, CTJ 200	T 2	222	240	70	19	108	16,3	29	9	8,5	27,5	M8	DIN 912	0,160	53051

**i** Recommended number of clamping fixtures: For T1 is recommended 6 pcs. per meter on each side, for T2 is recommended 3 pcs. per meter on each side and for T3 is recommended 3 pcs. per meter on each side.

## CENTERING RINGS

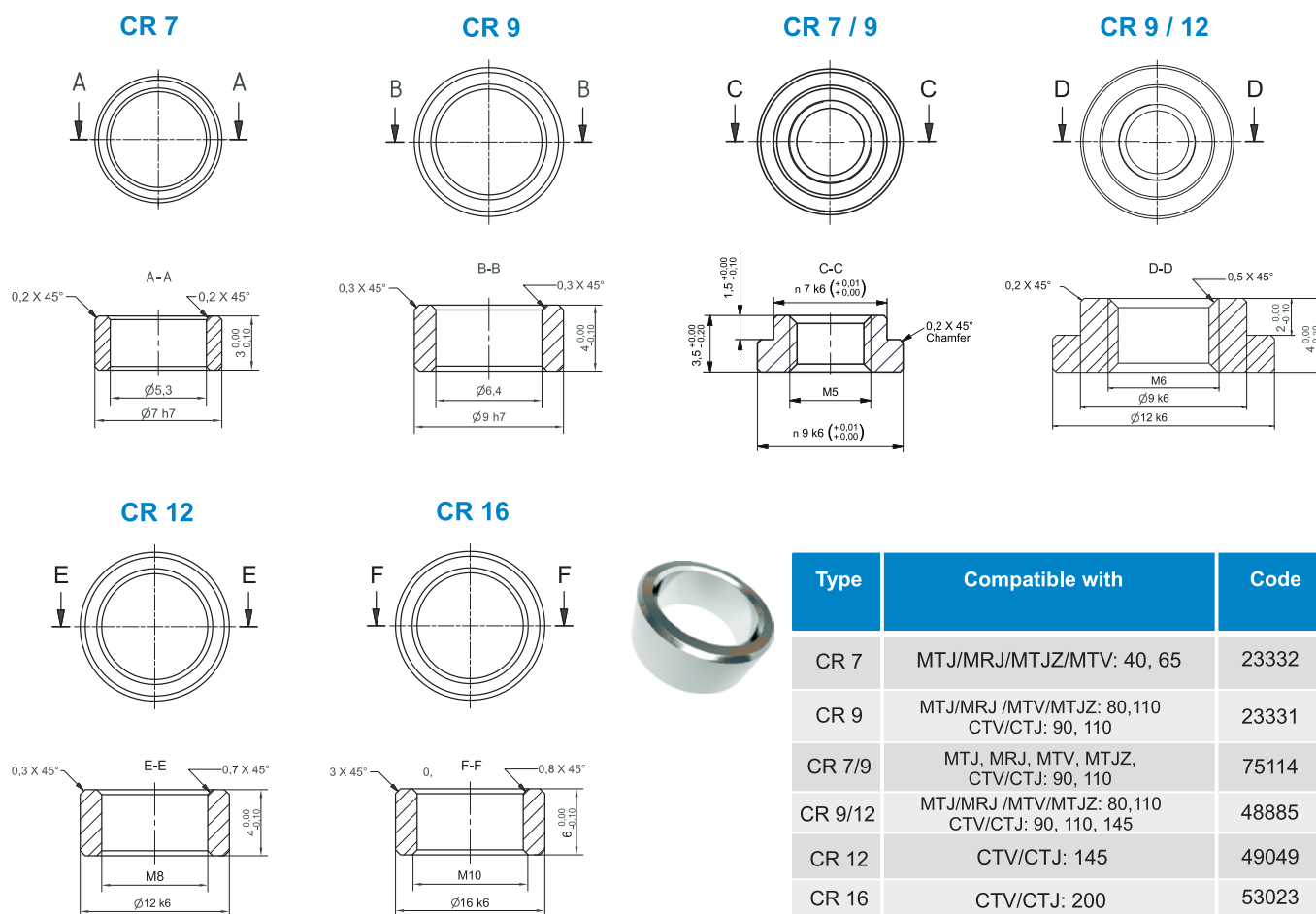

## SLOT NUTS



### LINEAR UNITS - PROFILE

DIN562

DIN557

Slot Nut

\* - deviating CODE

CODE	NUT TYPE	MTJ/MRJ 40	MTJ/MRJ/ MTV/MTJZ 65	MTJ/MRJ/ MTV/MTJZ 80	MTJ/MRJ/MTV MTJZ 110	MTJ 40 ECO	CTV 90 CTJ 90	CTV 110 CTJ 110	CTV 145 CTJ 145	CTV 200 CTJ 200
41609	DIN562 - M2,5						X	X	X	
40682	DIN562 - M4	X - *57017	X	X			X			X
40768	DIN562 - M5							X	X	
40769	DIN557 - M5		X	X						
44451	DIN557 - M8				X					X
5746	Slot Nut M6					X				
5551	Slot Nut T-10-M8									X
5552	Slot Nut T-10-M6									X
5553	Slot Nut T-10-M5									X
5570	Slot N. T-10-M8 L=90									X

### LINEAR UNITS - CONNECTION PLATES

CODE	NUT TYPE	CTV 200 CTJ 200	CODE	NUT TYPE	CTV 145 CTJ 145	CODE	NUT TYPE	CTV 110 CTJ 110	CTV 90 CTJ 90
5551	Slot Nut T-10-M8	X	5704	Slot Nut 8LM4	X	48887	Slot Nut 6LM4	X	X
5552	Slot Nut T-10-M6	X	5703	Slot Nut 8LM5	X	48888	Slot Nut 6LM5	X	X
5553	Slot Nut T-10-M5	X	5702	Slot Nut 8LM6	X				
5570	Slot Nut T-10-M8 L=90	X	5701	Slot Nut 8LM8	X				

**MAGNETIC FIELD SENSORS**

**MTJ / MRJ / MTV**

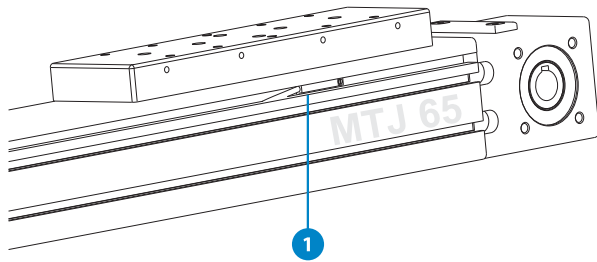

**CTV / CTJ**

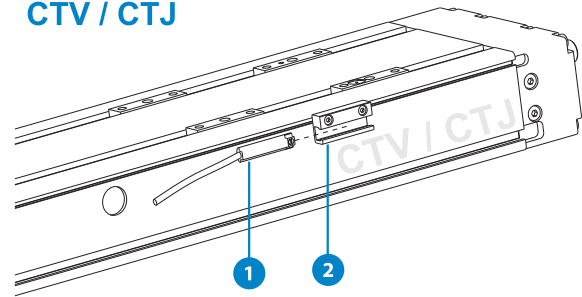

- 1 - Magnetic field sensor
- 2 - Sensor holder

**i** Mounting of Magnetic field sensor on **CTV** and **CTJ** series requires a HOM sensor holder. For CTV/CTJ 200 a HOM sensor holder is not needed.

**SMT-65TP-K NO / NC**

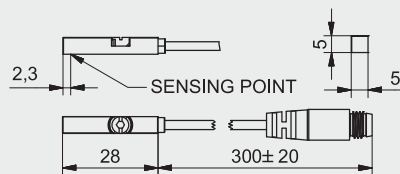

**Extension cable with connector**

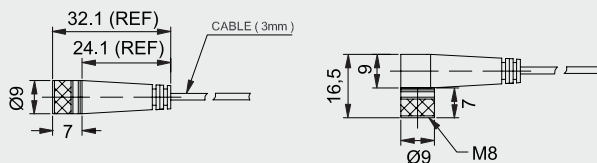

Code	Type	Compatibility	
43851	HOM Sensor holder	CTV90, CTV110, CTV145, CTJ90, CTJ110, CTJ145	
74073	SMT-65TP-K NC	MTJ/MRJ/MTV/MTJZ:40,65,80,110 CTV/CTJ: 200	
77075	SMT-65TP-K NC + HOM	CTV90, CTV110, CTV145 CTJ90, CTJ110, CTJ145	
74074	SMT-65TP-K NO	MTJ/MRJ/MTV/MTJZ:40,65,80,110 CTV/CTJ: 200	
77076	SMT-65TP-K NO + HOM	CTV90, CTV110, CTV145 CTJ90, CTJ110, CTJ145	
8146	Extension Cable length 2m - Straight connector		
8147	Extension Cable length 5m - Straight connector		
9017	Extension Cable length 2m - Angeled connector		
9019	Extension Cable length 5m - Angeled connector		

TECHNICAL DATA	SMT-65TP-K NC	SMT-65TP-K NO
<b>Sensor Type</b>	GMR sensor	GMR sensor
<b>Switching function</b>	NC	NO
<b>Output</b>	PNP	PNP
<b>Operating voltage</b>	10 ~ 28 V DC	10 ~ 28 V DC
<b>Switching Current</b>	200 mA max.	200 mA max.
<b>Power rating</b>	5,5 W max.	5,5 W max.
<b>Voltage Drop</b>	1,5 V / 200mA max.	1,5 V / 200 mA max.
<b>Current Consumption</b>	10 mA / 24 V max.	10 mA / 24 V max.
<b>Switching Frequency</b>	1000 Hz	1000 Hz
<b>Ambient temperature</b>	-10 ~ +70°C	-10 ~ +70°C
<b>Shock/Vibration</b>	50 G / 9 G	50 G / 9 G
<b>Protection class</b>	IP 67	IP 67
<b>LED indicator</b>	yellow	Yellow
<b>Electrical connection</b>	M8, 3-pin	M8, 3-pin
<b>Cable material length</b>	PU - 0,3 m	PU - 0,3 m
<b>Extension cable</b>	Energy chain compliant	Energy chain compliant



## MTJ / MRJ / MTV

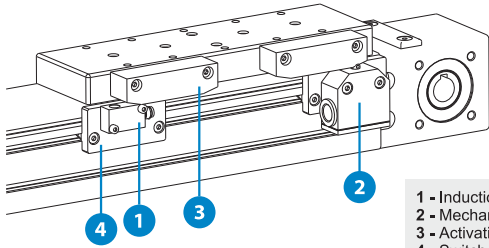

- 1 - Induction switch
- 2 - Mechanical switch
- 3 - Activation block
- 4 - Switch holder

## CTV / CTJ

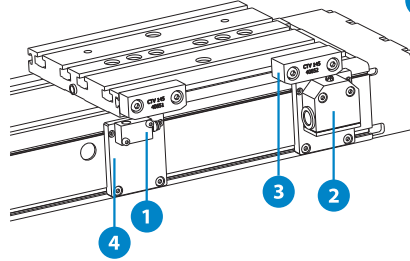

**i** Mounting and using the Induction and Mechanical switch, can be done only if the CTV and CTJ series Linear Units are delivered with Connection plates.

### MS- Mechanical switch

#### TECHNICAL DATA

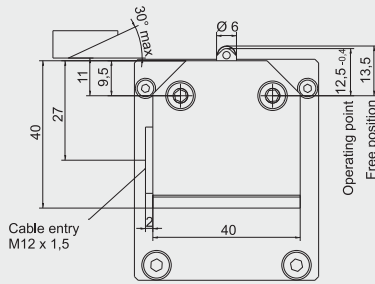

Protection class IEC 60529	IP 67
Ambient temperature	-5°C ...+80°C
Operating point accuracy	± 0.05 mm
Approach speed max.	45 m/min
Approach speed min.	0,01 m/min
Switching contact	1 changeover
Switching principle	Snap-action
Rated voltage	250 V AC
Switching current, min. at	10 mA
Switching voltage	24 V DC
Cable entry	M12 x 1,5

ORDERING CODES	MTJ/MRJ 40	MTJZ 40	MTJ/MRJ/MTV 65 MTJZ 65/80	MTJ/MRJ/MTV 80	MTJ/MRJ/MTV 110	MTJZ 110	MTJ ECO 40	CTV/CTJ 90	CTV/CTJ 110	CTV/CTJ 145	CTV/CTJ 200
+ 2x  Activation block with fixing screws	43243	52022	43247	43256	47827	63702	49030	49032	49031	40652	40652
Mechanical switch only	47921										
2x  + 2x  Mechanical switch with mounting elements	40683		40687	40689	47826	63703	49035	49034	49033	47939	53055

### IS- Inductive switch

#### TECHNICAL DATA

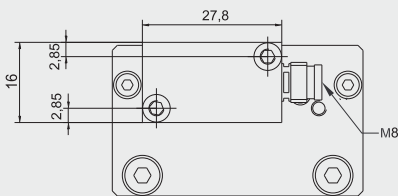

#### Extension cable with connector

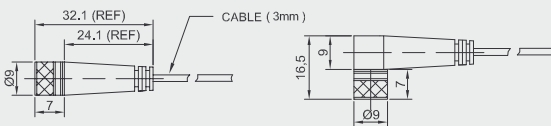

Sensor Type	PNP
Switching function	NC / NO
Rated voltage	10 ~ 30 V DC
Switching Current	150 mA max.
Ambient temperature	-25°C ...+70°C
Switching Frequency	800 Hz max.
Voltage Drop	3,5 V
Protection class	IP 67
Electrical connection	M8, 3-pin
Extension cable	Energy chain compliant - bending radius 75 mm
Cable material-length	PU
Cable length	2m / 5m
Cable length	M8, 3-pin Straight or Angeled connector

ORDERING CODES	MTJ/MRJ 40	MTJZ 40	MTJ/MRJ/MTV 65 MTJZ 65/80	MTJ/MRJ/MTV 80	MTJ/MRJ/MTV 110	MTJZ 110	MTJ ECO 40	CTV/CTJ 90	CTV/CTJ 110	CTV/CTJ 145	CTV/CTJ 200
+ 2x  Activation block with fixing screws	43243	52022	43247	43256	47827	63702	49030	49032	49031	40652	40652
PNP NO Inductive switch only	40671										
2x  +  PNP NO Ind. switch with mounting elements	40680		48026	43233	48047	63705	45105	49039	49038	48058	53054
PNP NC Inductive switch only	43570										
2x  +  PNP NC Ind. switch with mounting elements	48851		40685	47848	47989	63704	45103	49037	49036	47850	53052
Extension Cable length 2m - Straight connector										8146	
Extension Cable length 5m - Straight connector										8147	
Extension Cable length 2m - Angeled connector										9017	
Extension Cable length 5m - Angeled connector										9019	

**MOTOR ADAPTER WITH COUPLING**

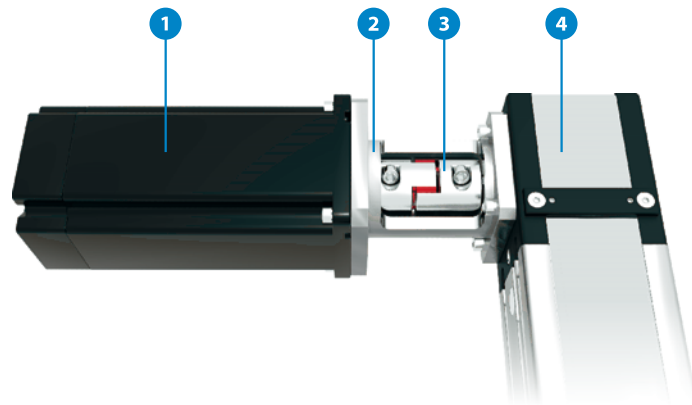

- 1 - Motor
- 2 - Motor adapter
- 3 - Coupling
- 4 - Linear Unit



Motor adapter : \_\_\_\_\_

Linear Unit : \_\_\_\_\_

Motor type : \_\_\_\_\_

According to customer's specification

Coupling type : \_\_\_\_\_

See page 8.020.0 or According to customer's specification

**COUPLINGS**



Coupling: \_\_\_\_\_

Coupling type / size: \_\_\_\_\_

7, 9, 14, 19/24, 24/28, 28/38, 38/45

Option:  
C: with keyway  
Leave blank: without keyway  
Hole diameter

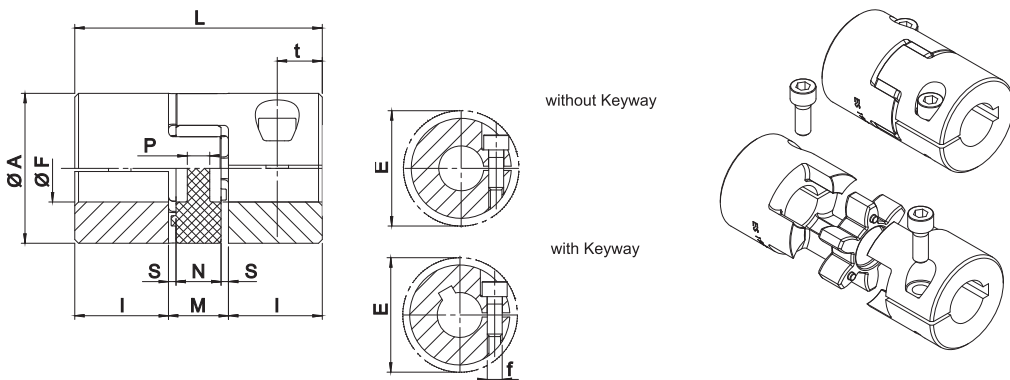

**i** The maximum transmittable torque of the clamping hub depends on the bore diameter (see the upper table on page 8.025.0).

Size	* T <sub>KN</sub> Nominal (Nm)	* T <sub>Kmax</sub> (Nm)	Ms (Nm)	W (Kg)	Hub J (Kg <sup>m2</sup> )	n <sub>max</sub> (min <sup>-1</sup> )	A (mm)	F (mm) [min]	F (mm) [max]	f (mm)	L (mm)	I (mm)	M (mm)	N (mm)	S (mm)	P (mm)	t (mm)	E (mm)
7	2	4	0,35	0,003	0,085 x 10	40.000	14	3	7	M2	22	7	8	6	1,0	6	4	15,0
9	5	10	0,75	0,007	0,42 x 10	28.000	20	4	10	M2,5	30	10	10	8	1,0	2	5	23,4
14	12,5	25	1,4	0,018	2,6 x 10	19.000	30	6	16	M3	35	11	13	10	1,5	2	5,5	32,2
19/24	17	34	11	0,071	18,1 x 10	14.000	40	10	20	M6	66	25	16	12	2,0	3,5	12	45,7
24/28	60	120	11	0,156	74,9 x 10	10.600	55	10	32	M6	78	30	18	14	2,0	4	12	56,4
28/38	160	320	25	0,240	163,9 x 10	8.500	65	14	35	M8	90	35	20	15	2,5	5,2	13,5	72,6
38/45	325	650	25	0,440	465,5 x 10	7.100	80	19	45	M8	114	45	24	18	3,0	5,6	16	83,3

\*The values of nominal T<sub>KN</sub>\*\* and max. T<sub>Kmax</sub>\*\* transmittable torque in the upper table are valid for coupling with Keyway!

\*\*for legend see page 8.025.0

Size	Recommended coupling bore diam. and Transmissible Torque (Nm) - valid for shaft tolerances k6 without Keyway																								
	Ø4	Ø5	Ø6	Ø7	Ø8	Ø9	Ø10	Ø11	Ø12	Ø14	Ø15	Ø16	Ø19	Ø20	Ø22	Ø24	Ø25	Ø28	Ø30	Ø32	Ø35	Ø38	Ø40	Ø42	Ø45
7	0,7	0,8	1	1,1																					
9	1,1	1,4	1,7	1,9	2,2	2,5	2,8																		
14			2,5	2,9	3,3	3,7	4,1	4,6	5	5,8	6,2	6,6													
19/24							23	25	27	32	34	36	43	45											
24/28							23	25	27	32	34	36	43	45	50	54	57	63							
28/38										58	62	66	79	83	91	100	104	116	124	133	145				
38/45													79	83	91	100	104	116	124	133	145	158	166	174	187

<b>Ms</b>	Screw tightening torque	Nm
<b>W</b>	Weight	Kg
<b>J</b>	Coupling moment of inertia	kgm <sup>2</sup>
<b>n<sub>max</sub></b>	Maximum rpm	min <sup>-1</sup>
<b>T<sub>KN</sub></b>	Coupling nominal torque	Nm
<b>T<sub>kmax</sub></b>	Coupling maximum torque	Nm

The operating temperature range for the coupling is between -30 and +90°C

## SYNCHRONISATION SHAFT OSL

**i** The maximum transmissible torque of the clamping hub depends on the bore diameter (see the upper table on page 8.025.0).

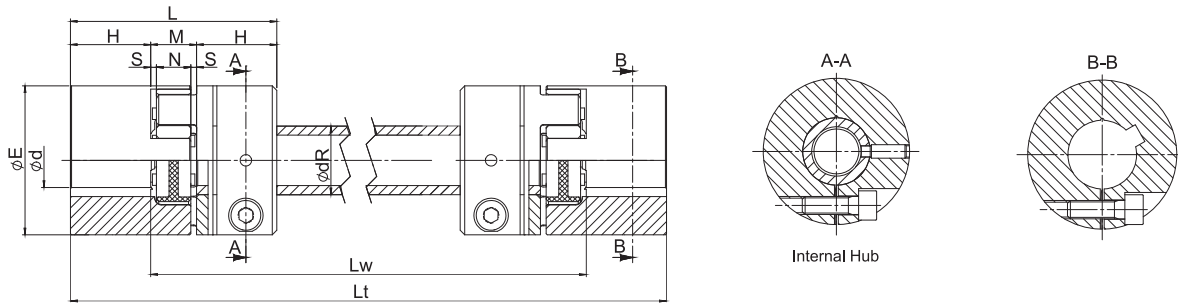

Size	Internal hub		C <sub>T</sub> (Nm/rad)	E (mm)	H (mm)	Ød min (mm)	Ød max (mm)	M (mm)	N (mm)	S (mm)	L (mm)	Lw min (mm)	Lt (mm)	dR x thickness (mm)	Weight (kg)	Moment of inertia (10 <sup>-6</sup> kg * m <sup>2</sup> )
	Ms (Nm)	M <sub>T</sub> (Nm)														
14	1,34	6	59	30	11	4	16	13	10	1,5	35	48	on request	14 x 2,0	0,072 + 0,00021 * Lw	10,4 + 0,0076 * Lw
19/24	10	34	314	40	25	6	20	16	12	2	66	82		20 x 3,0	0,284 + 0,00044 * Lw	72,4 + 0,0324 * Lw
24/28	10	45	596	55	30	8	28	18	14	2	78	96		25 x 2,5	0,624 + 0,00048 * Lw	300 + 0,0614 * Lw
28/38	25	105	2868	65	35	10	38	20	15	2,5	90	110		35 x 5,0	0,960 + 0,00128 * Lw	656 + 0,2954 * Lw
38/45	25	123	4521	80	45	12	45	24	18	3	114	138		40 x 5,0	1,760 + 0,00149 * Lw	1862 + 0,4656 * Lw

<b>Ms</b>	Screw tightening torque	Nm
<b>M<sub>T</sub></b>	Maximum transmissible torque	Nm
<b>C<sub>T</sub></b>	Torsional rigidity per meter	Nm/rad

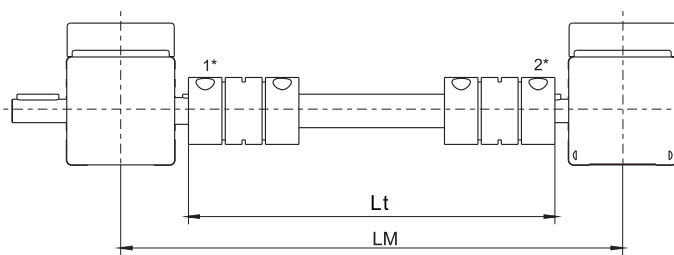

\* - see page 8.030.0 for more info

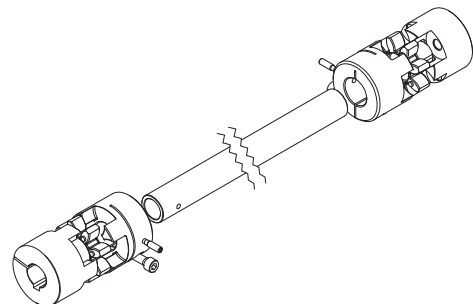

**i** For longer distances Bearing Supports needed. Please contact us.

**SYNCHRONISATION SHAFT OSR**

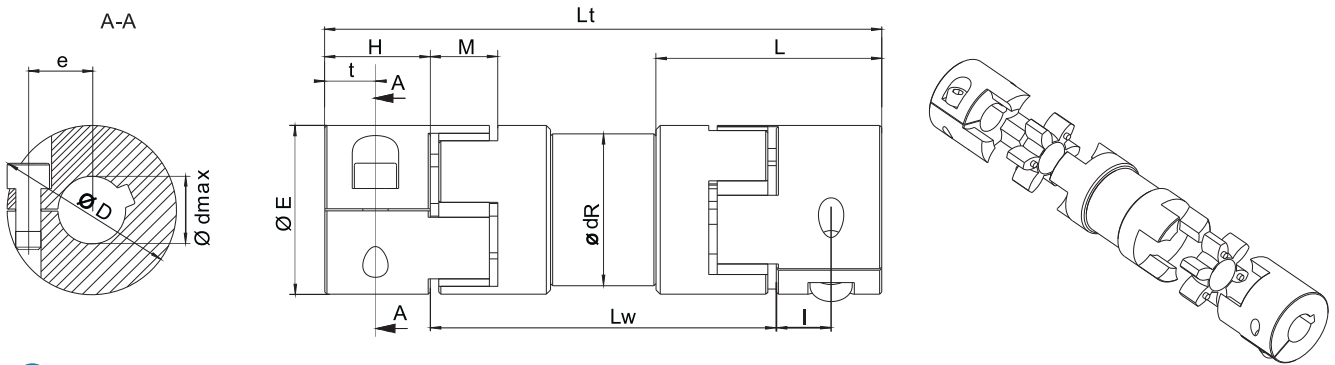

**i** The maximum transmittable torque of the clamping hub depends on the bore diameter (see the upper table on page 8.025.0).

Size	d min (mm)	d max (mm)	Ms (Nm)	Mt (Nm)	Ct (Nm/rad)	E (mm)	H (mm)	I (mm)	L (mm)	M (mm)	Lw min (mm)	Lt (mm)	D (mm)	t (mm)	e (mm)	dR (mm)	Weight (kg)	Moment of inertia (10 <sup>-6</sup> kg * m <sup>2</sup> )
19	10	20	10	39	1630	40	25	13	53,5	16	82	on request	47	12	15	36	0,30 + 0,00058 * Lw	66,0 + 0,1679 * Lw
24	10	28	10	53	3980	55	30	16	63	18	96		57	14	20,8	45	0,62 + 0,00091 * Lw	242 + 0,4099 * Lw
28	14	35	25	137	7494	65	35	20	67	20	110		73	15	25	55	0,98 + 0,00112 * Lw	572 + 0,7717 * Lw
38	15	45	25	180	14540	80	45	25	83,5	24	138		84	20	30	68	1,75 + 0,00140 * Lw	1522 + 1,4975 * Lw

**Ms** Screw tightening torque Nm  
**Mt** Maximum transmissible torque Nm  
**Ct** Torsional rigidity per meter Nm/rad

**INSTALLATION**

The overall length Lt is best determined as the distance between shaft ends - length Lw plus 2x dimension H.

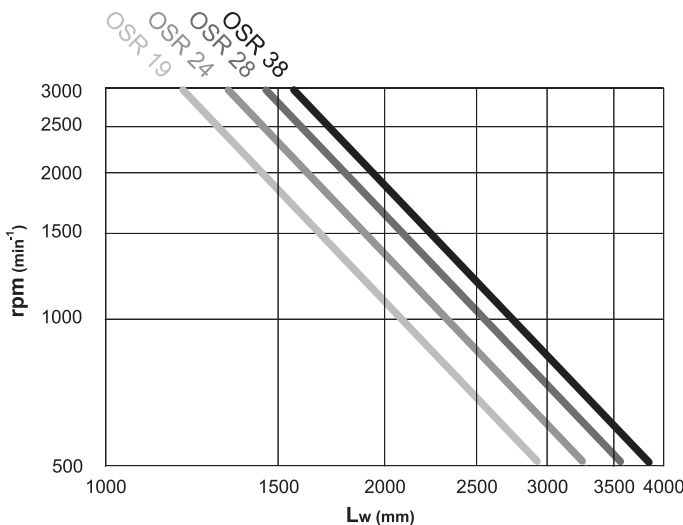
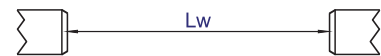

**SELECTION DIAGRAM**

Ideal execution for long distance shaft connections. Torque transmission is zero backlash. Designed for lengths up to 4m without bearing support (depending on rotation speed).

Standard lengths available till 3m, for longer lengths please contact us.

**HOW TO ORDER**

**OSR - 19 - MTJ65 - LM - 890 - F16C - F16C**

Type: OSR  
 Size: OSL: 14, 19/24, 24/28, 28/38, 38/45  
 OSR: 19, 24, 28, 38  
 Linear unit series: MTJ/MRJ/MTJ ECO: 40, 65, 80, 110  
 CTJ: 90, 110, 145, 200  
 Leave blank : not for linear unit  
 Length type: LM (Middle distance of the linear units)  
 Lt (Production length of the sync. shaft)

Option:  
**C:** with keyway  
**Leave blank:** w/o keyway  
**Hole diameter:**  
 — one side end hub<sup>1</sup><sub>2</sub>  
 --- other side end hub  
**Length [mm]**

**X-Y CONNECTION ELEMENTS**

**X- Axis MTJ, MRJ, MTV, MTJ ECO, CTV = 0° → Y Axis = 0°**

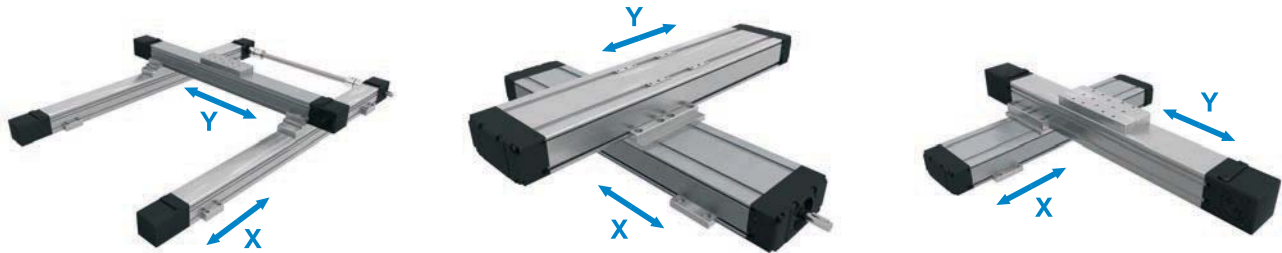

X-Axis	Y-Axis								
	MTJ, MRJ 40	MTJ, MRJ, MTV 65	MTJ, MRJ, MTV 80	MTJ, MRJ, MTV 110	MTJ 40 ECO	CTV, CTJ 90	CTV, CTJ 110	CTV, CTJ 145	CTV, CTJ 200
MTJ, MRJ 40	CP M40 0 M40 0	CP M40 0 M65 0			CP M40 0 E40 0	CP M40 0 C90 0			
MTJ, MRJ, MTV 65	CP M65 0 M40 0	CP M65 0 M65 0	CP M65 0 M80 0		CP M65 0 E40 0	CP M65 0 C90 0	CP M65 0 C110 0		
MTJ, MRJ, MTV 80		CP M80 0 M65 0	CP M80 0 M80 0	CP M80 0 M110 0		CP M80 0 C90 0	CP M80 0 C110 0	CP M80 0 C145 0	
MTJ, MRJ 110		CP M110 0 M65 0	CP M110 0 M80 0	CP M110 0 M110 0			CP M110 0 C110 0	CP M110 0 C145 0	CP M110 0 C200 0
MTJ 40 ECO	CP E40 0 M40 0	CP E40 0 M65 0	CP E40 0 M80 0		CP E40 0 E40 0	CP E40 0 C90 0	CP E40 0 C110 0		
CTV, CTJ 90	CP C90 0 M40 0	CP C90 0 M65 0				CP C90 0 C90 0	CP C90 0 C110 0		
CTV, CTJ 110	CP C110 0 M40 0	CP C110 0 M65 0	CP C110 0 M80 0			CP C110 0 C90 0	CP C110 0 C110 0	CP C110 0 C145 0	
CTV, CTJ 145		CP C145 0 M65 0	CP C145 0 M80 0	CP C145 0 M110 0		CP C145 0 C90 0	CP C145 0 C110 0	CP C145 0 C145 0	
CTV, CTJ 200			CP C200 0 M80 0	CP C200 0 M110 0			CP C200 0 C110 0	CP C200 0 C145 0	CP C200 0 C200 0

**X- Axis MTJ, MRJ, MTV, MTJ ECO, CTV = 0° → Y Axis = 90°**

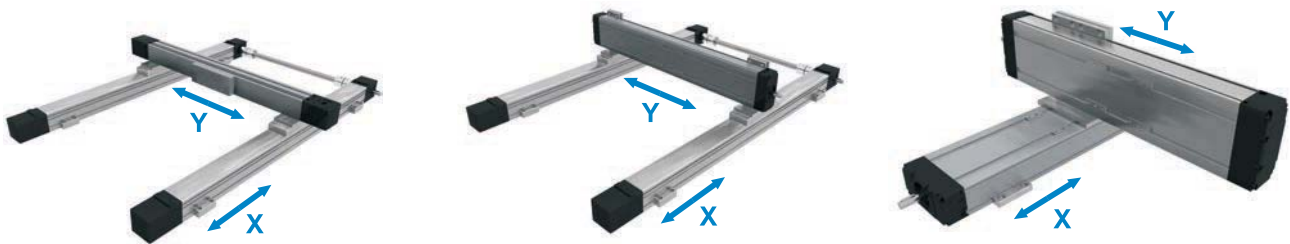

X-Axis	Y-Axis								
	MTJ, MRJ 40	MTJ, MRJ, MTV 65	MTJ, MRJ, MTV 80	MTJ, MRJ, MTV 110	MTJ 40 ECO	CTV, CTJ 90	CTV, CTJ 110	CTV, CTJ 145	CTV, CTJ 200
MTJ, MRJ 40	CP M40 0 M40 90	CP M40 0 M65 90			CP M40 0 E40 90	CP M40 0 C90 90			
MTJ, MRJ, MTV 65	CP M65 0 M40 90	CP M65 0 M65 90	CP M65 0 M80 90			CP M65 0 C90 90	CP M65 0 C110 90		
MTJ, MRJ, MTV 80		CP M80 0 M65 90	CP M80 0 M80 90	CP M80 0 M110 90		CP M80 0 C90 90	CP M80 0 C110 90	CP M80 0 C145 90	
MTJ, MRJ 110		CP M110 0 M65 90	CP M110 0 M80 90	CP M110 0 M110 90			CP M110 0 C110 90	CP M110 0 C145 90	CP M110 0 C200 90
MTJ 40 ECO	CP E40 0 M40 90	CP E40 0 M65 90	CP E40 0 M80 90		CP E40 0 E40 90	CP E40 0 C90 90	CP E40 0 C110 90		
CTV, CTJ 90	CP C90 0 M40 90	CP C90 0 M65 90				CP C90 0 C90 90			
CTV, CTJ 110	CP C110 0 M40 90	CP C110 0 M65 90	CP C110 0 M80 90			CP C110 0 C90 90	CP C110 0 C110 90		
CTV, CTJ 145		CP C145 0 M65 90	CP C145 0 M80 90	CP C145 0 M110 90		CP C145 0 C90 90	CP C145 0 C110 90	CP C145 0 C145 90	
CTV, CTJ 200			CP C200 0 M80 90	CP C200 0 M110 90			CP C200 0 C110 90	CP C200 0 C145 90	CP C200 0 C200 90

Y-Z CONNECTION ELEMENTS

Y- Axis MTJ, MRJ, MTV, MTJ ECO, CTV, CTJ = 0° → Z-Axis = 90°

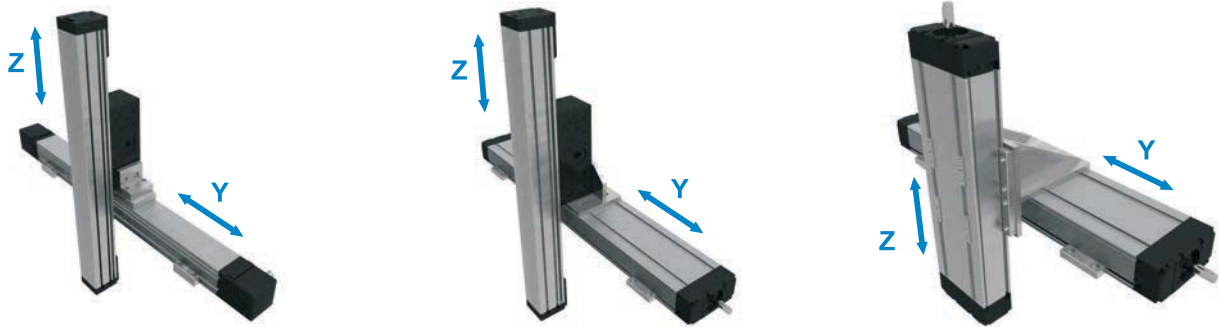

Y-Axis	Z-Axis									
	MTJZ 40	MTJZ 65	MTJZ 80	MTJZ 110	MTV 65	MTV 80	MTV 110	CTV 90	CTV 110	CTV 145
MTJ, MRJ 40	CP M40 0 Z40									
MTJ, MRJ, MTV 65	CP M65 0 Z40	CP M65 0 Z65			CP M65 0 ZM65					
MTJ, MRJ, MTV 80	CP M80 0 Z40	CP M80 0 Z65	CP M80 0 Z80		CP M80 0 ZM65	CP M80 0 ZM80				
MTJ, MRJ, MTV 110		CP M110 0 Z65	CP M110 0 Z80	CP M110 0 Z110	CP M110 0 ZM65	CP M110 0 ZM80	CP M110 0 ZM110			
MTJ 40 ECO	CP E40 0 Z40									
CTV, CTJ 90	CP C90 0 Z40	CP C90 0 Z65						CP C90 0 ZC90		
CTV, CTJ 110	CP C110 0 Z40	CP C110 0 Z65	CP C110 0 Z80		CP C110 0 ZM65	CP C110 0 ZM80		CP C110 0 ZC90	CP C110 0 ZC110	
CTV, CTJ 145	CP C145 0 Z40	CP C145 0 Z65	CP C145 0 Z80	CP C145 0 Z110	CP C145 0 ZM65	CP C145 0 ZM80	CP C145 0 ZM110	CP C145 0 ZC90	CP C145 0 ZC110	CP C145 0 ZC145
CTV, CTJ 200			CP C200 0 Z80	CP C200 0 Z110		CP C200 0 ZM80	CP C200 0 ZM110		CP C200 0 ZC110	CP C200 0 ZC145

CONNECTION ELEMENTS FOR CUNSTRICIONS WITH ALU PROFILES



**i** Linear Unit must be mounted by the aluminium profile and not at the end blocks!

For more details about Alu profiles see **PROFILE TECHNIC** catalogue.



## MULTI AXIS SYSTEMS

We offer all necessary fittings including brackets, clamping fixtures and adapter plates in order to build multi-axis systems. Beside standard elements we supply also custom fixing and connection elements manufactured in our workshop.

1



2



3



4



5



6



MULTI AXIS SYSTEMS



7



8



9



10